



SERVICE MANUAL

UHF TRANSCEIVER

IC-F61 (ATEX VERSION)

S-14219MZ-C1

Jan. 2006

Icom Inc.

CAUTION

The repair and maintenance of an ATEX approved transceiver can only be performed in an ATEX approved repair facility. The ATEX approval will be canceled if ATEX intrinsically safe radios are repaired anywhere else except in an approved facility.

INTRODUCTION

This service manual describes the latest service information for the **IC-F61** UHF TRANSCEIVER at the time of publication.

MODEL	VERSION	SYMBOL	I/S	TX HI-POWER
IC-F61	Europe	EUR	ATEX	5W

To upgrade quality, all electrical or mechanical parts and internal circuits are subject to change without notice or obligation.

DANGER

NEVER connect the transceiver to an AC outlet or to a DC power supply that uses more than 8 V. Such a connection could cause a fire or electric hazard.

DO NOT expose the transceiver to rain, snow or any liquids.

DO NOT reverse the polarities of the power supply when connecting the transceiver.

DO NOT apply an RF signal of more than 20 dBm (100 mW) to the antenna connector. This could damage the transceiver's front end.

ORDERING PARTS

Be sure to include the following four points when ordering replacement parts:

1. 10-digit order numbers
2. Component part number and name
3. Equipment model name and unit name
4. Quantity required

<SAMPLE ORDER>

5030002630 LCD L3-0048TAY-2 IC-F61 Front unit 5 pieces
8810010120 Screw BO 2x8 SUS ZK IC-F61 Chassis 10 pieces

Addresses are provided on the inside back cover for your convenience.

REPAIR NOTES

1. Make sure a problem is internal before disassembling the transceiver.
2. **DO NOT** open the transceiver until the transceiver is disconnected from its power source.
3. **DO NOT** force any of the variable components. Turn them slowly and smoothly.
4. **DO NOT** short any circuits or electronic parts. An insulated turning tool **MUST** be used for all adjustments.
5. **DO NOT** keep power ON for a long time when the transceiver is defective.
6. **DO NOT** transmit power into a signal generator or a sweep generator.
7. **ALWAYS** connect a 30 dB to 40 dB attenuator between the transceiver and a deviation meter or spectrum analyzer when using such test equipment.
8. **READ** the instructions of test equipment thoroughly before connecting equipment to the transceiver.

Icom, Icom Inc. and ICOM logo are registered trademarks of Icom Incorporated (Japan) in the United States, the United Kingdom, Germany, France, Spain, Russia and/or other countries.



TABLE OF CONTENTS

SECTION 1 SPECIFICATIONS

SECTION 2 INSIDE VIEWS

SECTION 3 DISASSEMBLY INSTRUCTIONS

SECTION 4 CIRCUIT DESCRIPITON

4-1	RECEIVER CIRCUITS	4-1
4-2	TRANSMITTER CIRCUITS	4-2
4-3	PLL CIRCUITS	4-3
4-4	POWER SUPPLY CIRCUITS	4-4
4-5	OTHER CIRCUITS	4-5
4-6	PORT ALLOCATIONS	4-5

SECTION 5 ADJUSTMENT PROCEDURES

5-1	PREPARATION	5-1
5-2	SOFTWARE ADJUSTMENTS	5-4

SECTION 6 PARTS LIST

SECTION 7 MECHANICAL PARTS AND DISASSEMBLY

SECTION 8 SEMI-CONDUCTOR INFORMATION

SECTION 9 BOARD LAYOUTS

9-1	MAIN UNIT	9-1
9-2	FRONT UNIT	9-3
9-3	VR UNIT	9-5
9-4	CONNECTOR UNIT	9-6

SECTION 10 BLOCK DIAGRAM

SECTION 11 VOLTAGE DIAGRAM

11-1	MAIN UNIT	11-1
11-2	FRONT UNIT	11-2
11-3	VR UNIT / CONNECTOR UNIT	11-3

SECTION 12 CONTACT SPRING ASSEMBLY INSTRUCTION

SECTION 1 SPECIFICATIONS

■ GENERAL

- Frequency coverage : 136.000–174.000 MHz
- Type of emission : Wide : 16K0F3E (25.0 kHz)
Middle : 14K0F3E (20.0 kHz)
Narrow : 8K50F3E (12.5 kHz)
- Number of conventional channels : 128 ch (Divided into 8 banks)
- Antenna connector : SMA type (50 Ω)
- Operating temperature range : –25°C to +55°C
- Power supply requirement : 7.2 V DC nominal (negative ground)
- Current drain (at 7.2 V DC) :

RECEIVING		TRANSMITTING
Stand-by	Max. audio	
85 mA	300 mA	0.7 A

- Dimensions (projections not included) : 56.0(W)×97.0(H)×36.4(D) mm
- Weight (Including BP-227) : Approximately 280 g

■ TRANSMITTER

- Output power (at 7.2 V DC) : 1 W
- Modulation : Variable reactance frequency modulation
- Maximum permissible deviation : ±5.0 kHz (Wide), ±4.0 kHz (Middle), ±2.5 kHz (Narrow)
- Frequency error : ±2.5 ppm
- Spurious emissions : 0.25 μW (≤ 1 GHz), 1.0 μW (≥ 1 GHz)
- Adjacent channel power : 70 dB min. (Wide, Middle), 60 dB min. (Narrow)
- Audio harmonic distortion : 3 % typical (AF 1kHz, 40 % deviation)
- Residual modulation (with CCITT filter) : 45 dB min (55 dB typical) for Wide
43 dB min (53 dB typical) for Middle
40 dB min (50 dB typical) for Narrow
- Limiting charact of modulator : 60–100 % of maximum deviation
- Microphone impedance : 2.2 kΩ

■ RECEIVER

- Receive system : Double conversion superheterodyne system
- Intermediate frequencies : 1st IF: 46.35 MHz, 2nd IF: 450 kHz
- Sensitivity : 0.63 μV (–111 dBm) emf typical at 20 dB SINAD
- Squelch sensitivity (at threshold) : 0.63 μV (–111 dBm) emf typical
- Adjacent channel selectivity : 70 dB min (75 dB typical) for Wide and Middle
60 dB min (65 dB typical) for Narrow
- Spurious response : 70 dB
- Intermodulation rejection ratio : 65 dB min (67 dB typical)
- Residual modulation (with CCITT filter) : 45 dB min (55 dB typical) for Wide
43 dB min (53 dB typical) for Middle
40 dB min (50 dB typical) for Narrow
- Audio output power : 0.5 W typical at 5% distortion with an 8 Ω load
- Output impedance (Audio) : 8 Ω

Specifications are measured in accordance with EN 300 086.

All stated specifications are subject to change without notice or obligation.

SECTION 2 INSIDE VIEWS

● MAIN UNIT

TOP VIEW

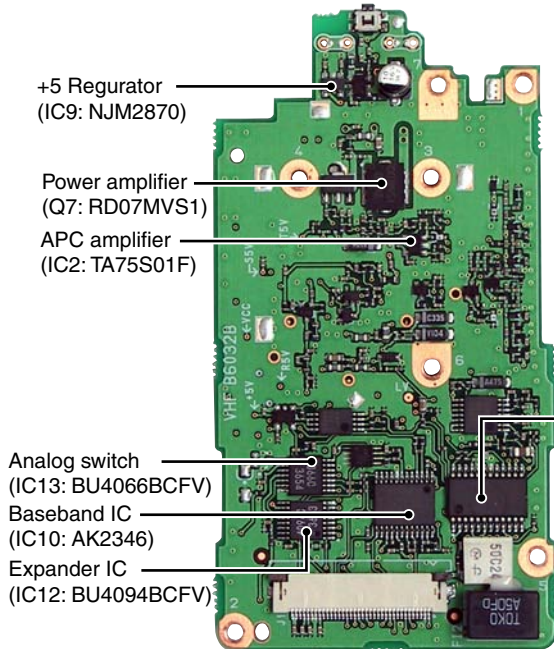

BOTTOM VIEW

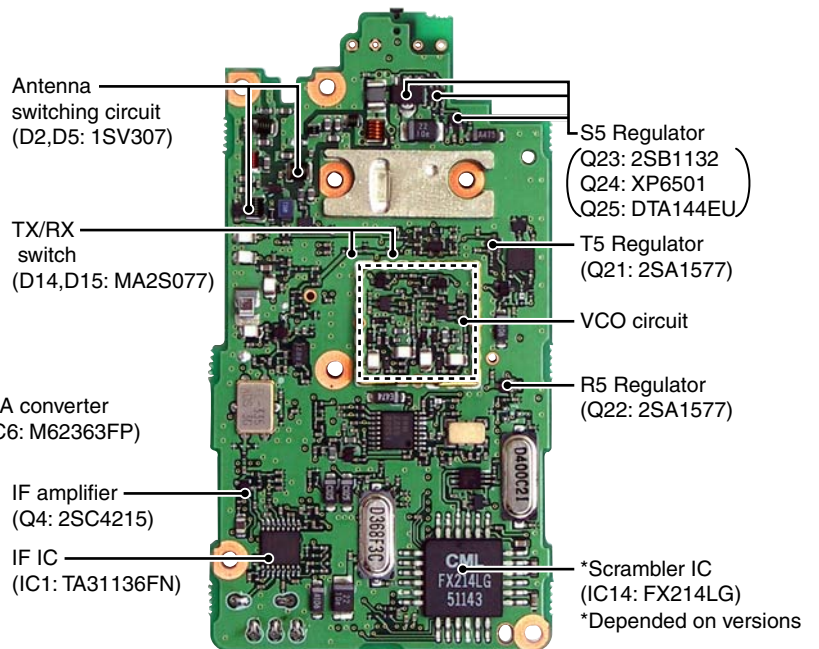

● FRONT UNIT

TOP VIEW

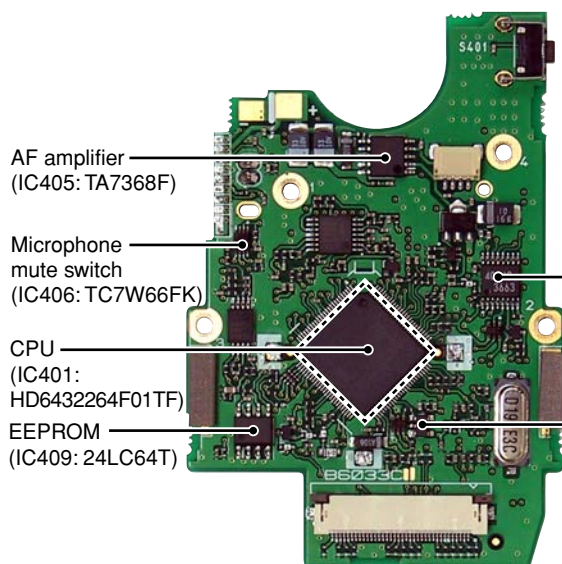

BOTTOM VIEW

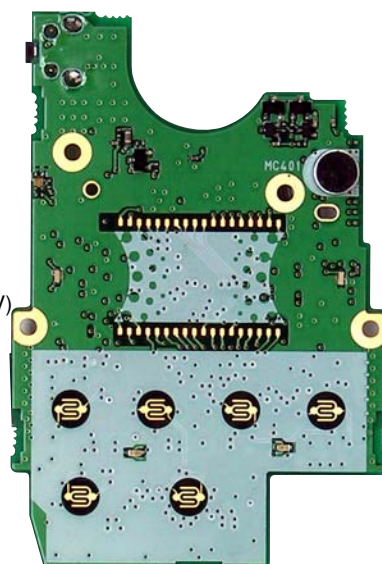

SECTION 3 DISASSEMBLY INSTRUCTIONS

● REMOVING THE CHASSIS UNIT

- ① Unscrew 1 nut (A), and remove 1 knob (B).
- ② Remove 1 washer (C), and unscrew 1 screw (D).
- ③ Unscrew 2 screws (E), and remove 2 washers (F).
- ④ Unscrew 2 screws (G).
- ⑤ Take off the chassis unit in the direction of the arrow.
- ⑥ Remove the cable (H) from the chassis unit.

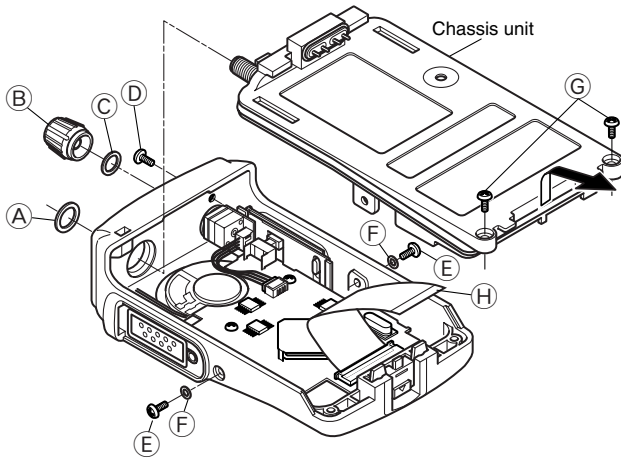

● REMOVING THE FRONT UNIT

- ① Unscrew 4 screws (M).
- ② Unsolder 11 points (N).
- ③ Unplug the connector (O) from J402 on the Front unit.
- ④ Take off the front unit in the direction of the arrow.

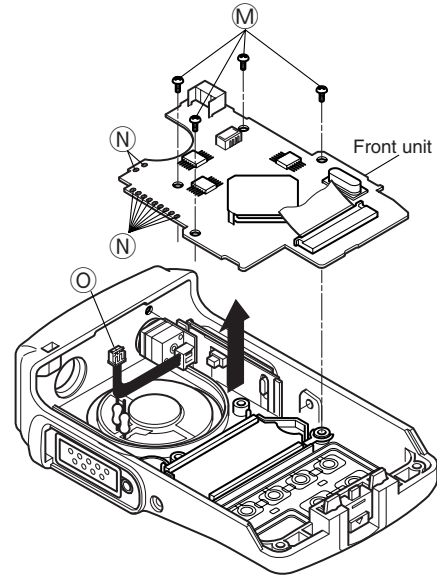

● REMOVING THE MAIN UNIT

- ① Unscrew 2 screws (I).
- ② Unsolder 5 points (J), and remove the shield cover.
- ③ Unscrew 5 screws (K).
- ④ Unsolder 3 points (L), and take off the main unit in the direction of the arrow.

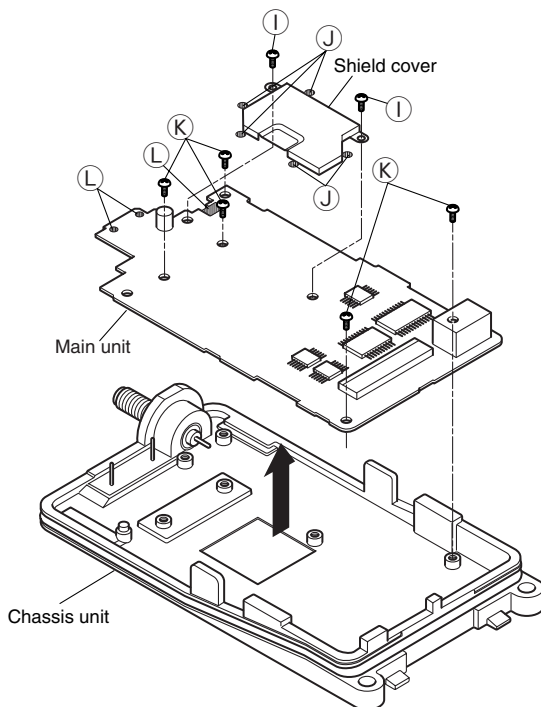

SECTION 4 CIRCUI T DESCRIPTION

4-1 RECEIVER CIRCUITS

4-1-1 ANTENNA SWITCHING CIRCUIT (MAIN UNIT)

The antenna switching circuit functions as a low-pass filter while receiving and a resonator circuit while transmitting. This circuit does not allow transmit signals to enter the receiver circuits.

Received signals enter the antenna connector (CHASSIS; J1) and pass through the low-pass filter (L1, L2, L45, C1 -C5, C365). The filtered signals are passed through the $\lambda/4$ type antenna switching circuit (D2, D5, L5) and then applied to the RF circuit.

4-1-2 RF CIRCUIT (MAIN UNIT)

The RF circuit amplifies signals within the range of frequency coverage and filters out-of-band signals.

The signals from the antenna switching circuit pass through the two-stage tunable bandpass filters (D3, D4, D7, D8, L7, L8). The filtered signals are amplified at the RF amplifier (Q2) and then passed through the another two-stage tunable bandpass filters (D9, D10, L9, L11) to suppress unwanted signals. The filtered signals are applied to the 1st mixer circuit.

D3, D4, D7-D10 employ varactor diodes, that are controlled by the CPU via the D/A converter (IC6), to track the bandpass filter. These varactor diodes tune the center frequency of an RF pass band for wide bandwidth receiving and good image response rejection.

4-1-3 1ST MIXER AND 1ST IF CIRCUITS (MAIN UNIT)

The 1st mixer circuit converts the received signal into fixed frequency of the 1st IF signal with the PLL output frequency. By changing the PLL frequency, only the desired frequency passes through a crystal filter at the next stage

of the 1st mixer.

The RF signals from the bandpass filter are mixed with the 1st LO signals, where come from the RX VCO circuit via the low-pass filter (L38, C363, C364), at the 1st mixer circuit (Q3) to produce a 46.35 MHz 1st IF signal. The 1st IF signal is passed through a monolithic filter (F11) in order to obtain selection capability and to pass only the desired signals. The filtered signal is applied to the 2nd IF circuit after being amplified at the 1st IF amplifier (Q4).

4-1-4 2ND IF AND DEMODULATOR CIRCUITS (MAIN UNIT)

The 2nd mixer circuit converts the 1st IF signal into a 2nd IF signal. The double-conversion superheterodyne system (which convert receive signals twice) improves the image rejection ratio and obtains stable receiver gain.

The 1st IF signal from the IF amplifier (Q4) is applied to the 2nd mixer section of the FM IF IC (IC1, pin 16), and is mixed with the 2nd LO signal to be converted into a 450 kHz 2nd IF signal.

The FM IF IC (IC1) contains the 2nd mixer, 2nd local oscillator, limiter amplifier, quadrature detector, active filter and noise amplifier circuits. A 2nd LO signal (45.9 MHz) is produced at the PLL circuit by tripling it's reference frequency (15.3 MHz).

The 2nd IF signal from the 2nd mixer (IC1, pin 3) passes through the ceramic filter (FI2) to remove unwanted heterodyned frequencies. It is then amplified at the limiter amplifier section (IC1, pin 5) and applied to the quadrature detector section (IC1, pins 10, 11) to demodulate the 2nd IF signal into AF signals.

The demodulated AF signals are output from pin 9 (IC1) and applied to the AF circuit via the receiver mute circuit.

• 2ND IF AND DEMODULATOR CIRCUITS

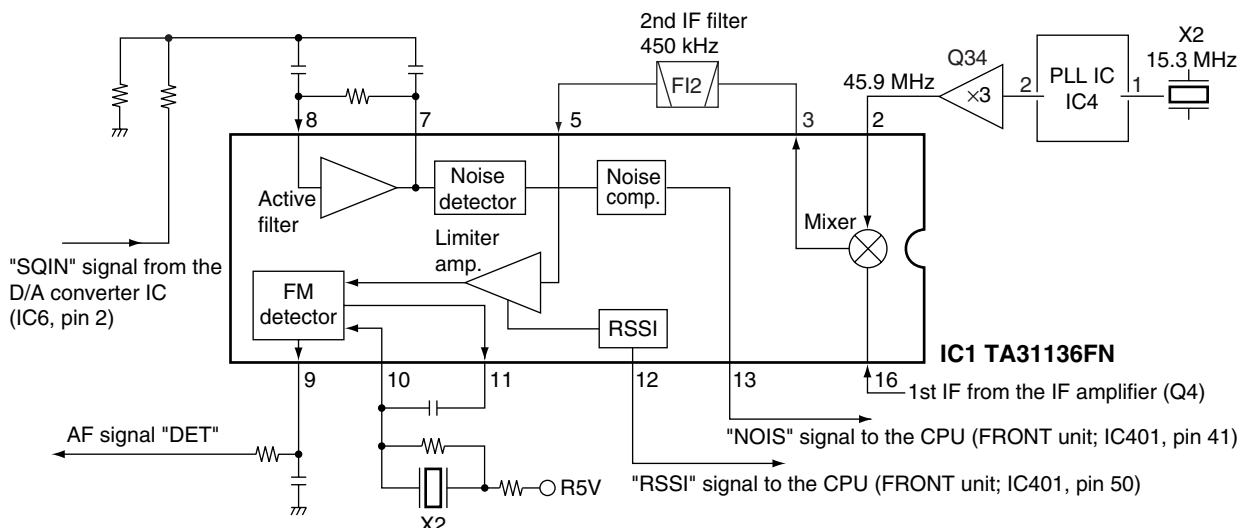

4-1-5 AF AMPLIFIER CIRCUIT (MAIN AND FRONT UNITS)

The AF amplifier circuit amplifies the demodulated AF signals to drive a speaker. This transceiver employs the base band IC which is composed of pre-amplifier, expander, scrambler, MSK de-modulator, etc. at the AF amplifier section.

The AF signals from the FM IF IC (IC1, pin 9) are amplified at the AF amplifier section of the base band IC (IC10, pin 23) and are then applied to the low-pass filter section of it.

The filtered signals pass through the high-pass filter to suppress unwanted harmonic components. The signals pass through (or bypass) scrambler and expander sections, and are then applied to (or bypass) the scrambler IC (IC14) via the analog switch (IC13). The signals are amplified at the amplifier section of the base band IC (IC10), and pass through the AF mute switch (IC406) and low-pass filter (IC403). The filtered signals pass through the AF volume, and are then applied to the AF power amplifier (IC405) to drive the speaker.

4-1-6 RECEIVE MUTE CIRCUITS (MAIN AND FRONT UNITS)

• NOISE SQUELCH

A squelch circuit cuts out AF signals when no RF signals are received. By detecting noise components in the AF signals, the squelch circuit switches the AF mute switch.

Some noise components in the AF signals from the FM IF IC (IC1, pin 9) are passed through the D/A converter (IC6, pin 1). The signals are applied to the active filter section in the FM IF IC (IC1, pin 8). Noise components about 10 kHz are amplified and output from pin 7.

The filtered signals are converted into the pulse-type signals at the noise detector section and output from pin 13 (NOIS).

The "NOIS" signal from the FM IF IC is applied to the CPU (FRONT unit; IC401, pin 41). Then the CPU analyzes the noise condition and controls the AF mute signal via "AFON" line from expander IC (FRONT unit; IC410, pin 7) to the AF power controller (FRONT unit; Q401, Q402).

• CTCSS AND DTCS

The tone squelch circuit detects AF signals and opens the squelch only when receiving a signal containing a matching subaudible tone (CTCSS or DTCS). When tone squelch is in use, and a signal with a mismatched or no subaudible tone is received, the tone squelch circuit mutes the AF signals even when noise squelch is open.

A portion of the "DET" AF signals from the FM IF IC (IC1, pin 9) passes through the low-pass filter (IC5, pin 5) to remove AF (voice) signals, and are then applied to the amplifier (MAIN unit; IC5, pin 10). The amplified signals are applied to the CTCSS or DTCS decoder inside of the CPU (FRONT unit; IC401, pin 44) via the "CDEC" line. The CPU outputs AF mute control signal, and is then applied to the I/O expander IC (FRONT unit; IC410). The IC outputs AF mute circuit (FRONT unit; IC406) and AF power supply circuits (FRONT unit; Q401, Q402) control signals via the "AFON" line.

4-2 TRANSMITTER CIRCUITS

4-2-1 MICROPHONE AMPLIFIER CIRCUIT (FRONT AND MAIN UNITS)

The microphone amplifier circuit amplifies audio signals within +6 dB/octave pre-emphasis characteristics from the microphone to a level needed for the modulation circuit.

This transceiver employs the base band IC which is composed of microphone amplifier, compressor, scrambler, limiter, splatter filter, MSK modulator, etc. at the microphone amplifier section.

The AF signals (MIC) from the microphone (MC401) are passed through the microphone mute switch (IC406, pins 2, 1), and are then applied to the amplifier (IC407, pins 2, 6). The amplified signals pass through (or bypass) the scrambler IC (MAIN unit; IC14) via the analog switch (MAIN unit; IC13), and are then applied to the microphone amplifier section of the base band IC (MAIN unit; IC10, pins 3, 4). The amplified signals are passed through or bypass the compressor, scrambler sections of IC10 (MAIN unit), and are then passed through the high-pass, limiter amplifier, splatter filter sections of IC10 (MAIN unit).

• AF AMPLIFIER AND MICROPHONE AMPLIFIER CIRCUITS

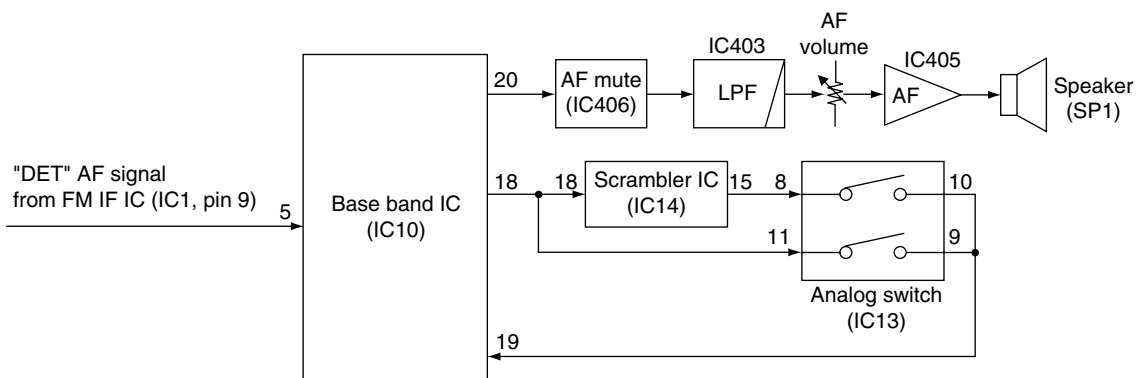

The filtered AF signals are applied to the FM/PM switch (MAIN unit; IC11, pin 6), and pass through the low-pass filter (MAIN unit; IC5, pin 1). The amplified signals are applied to the D/A converter (MAIN unit; IC6, pin 4). The output signals from the D/A converter (MAIN unit; IC6, pin 3) are applied to the modulation circuit (MAIN unit; D18).

4-2-2 MODULATION CIRCUIT (MAIN UNIT)

The modulation circuit modulates the VCO oscillating signal (RF signal) using the microphone audio signals.

The AF signals from the D/A converter (IC6, pin 3) change the reactance of varactor diode (D18) to modulate the oscillated signal at the TX VCO circuit (Q14, D17). The modulated VCO signal is amplified at the buffer amplifiers (Q10, Q11) and is then applied to the drive amplifier circuit via the T/R switch (D14).

The CTCSS/DTCS signals ("CENC0", "CENC1", "CENC2" from the CPU (FRONT unit; IC401, pins 79–81) pass through the low-pass filter (IC403, pins 1, 3), and are then applied to the D/A converter via the "CDCS" line (IC6, pin 9). The output signal from the D/A converter (IC6, pin 10) passes through the low-pass filter (IC5, pins 1, 2). The CTCSS/DTCS signals are mixed with "MOD" signal at the low-pass filter (IC5), and are then applied to the D/A converter again (IC6, pin 4).

4-2-3 DRIVE/POWER AMPLIFIER CIRCUITS

The drive/power amplifier circuits amplify the VCO oscillating signal to an output power level.

The signal from the VCO circuit passes through the T/R switch (D14), and is amplified at the YGR (Q5, Q9), drive (Q8), power (Q7) amplifiers to obtain 4 W of RF power (at 7.2 V DC).

The amplified signal is passed through the low-pass filter (L4, C12, C13, C16), power detector (D1, D39), antenna switching circuit (D2) and other low-pass filter (L1, L2, L45, C1–C5, C365), and is then applied to the antenna connector (CHASSIS unit; J1).

The bias current of the drive (Q8) and power (Q7) amplifiers are controlled by the APC circuit.

4-2-4 APC CIRCUIT (MAIN UNIT)

The APC circuit (IC2, D1, D39) protects the drive and power amplifiers from excessive current drive, and selects output power of HIGH, LOW2 or LOW1.

The power detector circuit (D1, D39) detects the transmit power output level and converts it into DC voltage. The output voltage is at a minimum level when the antenna impedance is matched at 50 Ω and is increased when it is mismatched.

The detected voltage is applied to the differential amplifier (IC2, pin 3), and the "T2" signal from the D/A converter (IC6, pin 14), controlled by the CPU (FRONT unit; IC401), is applied to the other input for reference. When antenna impedance is mismatched, the detected voltage exceeds the power setting voltage. Then the output voltage of the differential amplifier (IC2, pin 4) controls the input current of the drive (Q8) and power (Q7) amplifiers to reduce the output power.

4-3 PLL CIRCUITS

4-3-1 PLL CIRCUIT (MAIN UNIT)

A PLL circuit provides stable oscillation of the transmit frequency and receive 1st LO frequency. The PLL output compares the phase of the divided VCO frequency to the reference frequency. The PLL output frequency is controlled by the divided ratio (N-data) of a programmable divider.

The PLL circuit contains the TX/RX VCO circuits (Q13, Q14, D16, D17). The oscillated signal is amplified at the buffer amplifiers (Q11, Q12) and then applied to the PLL IC (IC4, pin 8) after being passed through the low-pass filter (L32, C206, C208).

The PLL IC contains a prescaler, programmable counter, programmable divider and phase detector, etc. The entered signal is divided at the prescaler and programmable counter section by the N-data ratio from the CPU. The divided signal is detected on phase at the phase detector using the reference frequency.

If the oscillated signal drifts, its phase changes from that of the reference frequency, causing a lock voltage change to compensate for the drift in the oscillated frequency.

• APC CIRCUIT

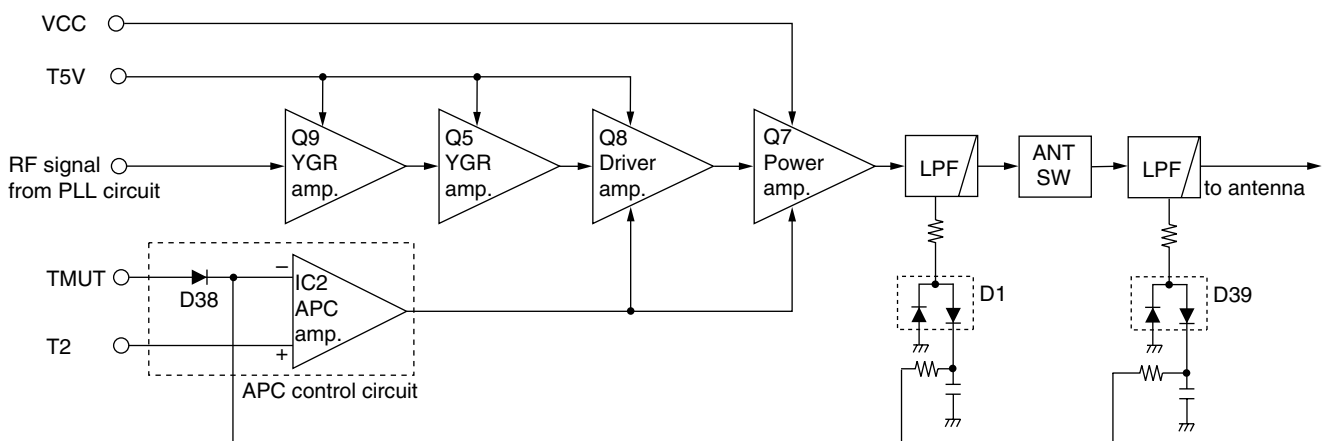

4-3-2 VCO CIRCUIT (MAIN UNIT)

The VCO circuit contains a separate RX VCO (Q13, D16) and TX VCO (Q14, D17). The oscillated signal is amplified at the buffer amplifiers (Q10, Q11) and is then applied to the T/R switch (D14, D15). Then the receive 1st LO (Rx) signal is applied to the 1st mixer (Q3) and the transmit (Tx) signal to the YGR amplifier circuit (Q9).

A portion of the signal from the buffer amplifier (Q11) is fed back to the PLL IC (IC4, pin 8) via the buffer amplifier (Q12) as the comparison signal.

4-4 POWER SUPPLY CIRCUIT

4-4-1 MAIN UNIT VOLTAGE LINE

LINE	DESCRIPTION
VCC	The voltage from the connected battery pack.
+5V	Common 5 V converted from the VCC line at the +5 regulator circuit (IC9). The output voltage is supplied to buffer amplifiers (Q18), FRONT unit, etc.
S5V	Common 5 V converted from the VCC line at the S5 regulator circuit (Q23–Q25). The output voltage is supplied to the ripple filter (Q17), PLL IC (IC4), FRONT unit, etc.
R5V	Receive 5 V converted from the S5V line at the R5 regulator circuit (Q22). The output voltage is supplied to the tripler (Q34), FM IF IC (IC1), IF amplifier (Q4), VCO switch (Q15, Q16), 1st mixer (Q3), etc.
T5V	Transmit 5 V converted from the S5V line at the T5 regulator circuit (Q21). The output voltage is supplied to the YGR amplifier (Q5, Q9), drive amplifier (Q8), APC amplifier (IC2), etc..

4-4-2 FRONT UNIT VOLTAGE LINE

LINE	DESCRIPTION
VCC	Same voltage as VCC line on the MAIN unit is applied to the FRONT unit via the J401, pins 1, 2 (FRONT unit). The voltage is supplied to the [PWR] switch controller (Q401, Q402).
CPU5	Same voltage as +5V line on the MAIN unit is applied to the FRONT unit via the J401, pin 4 (FRONT unit). The voltage is supplied to the CPU (IC401), reset IC (IC408), etc.
S5V	Same voltage as S5V line on the MAIN unit is applied to the FRONT unit via the J401, pin 5 (FRONT unit). The voltage is supplied to the mic mute circuit (IC406), AF mute circuit (Q403-Q406, IC406), etc.

• PLL CIRCUIT

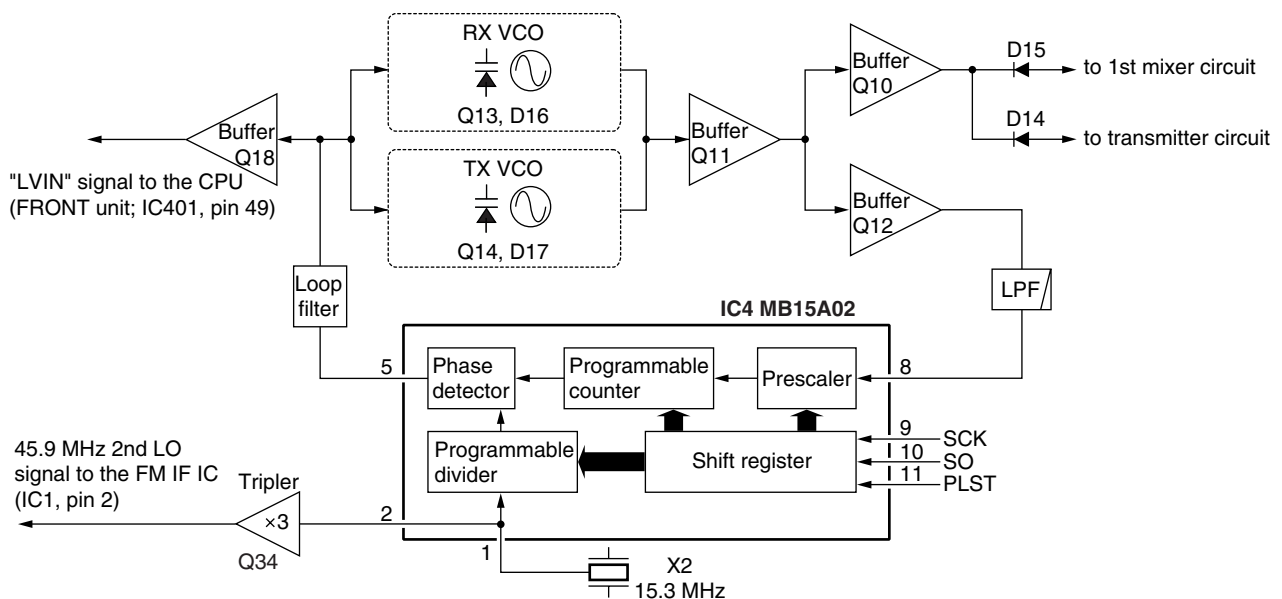

4-5 OTHER CIRCUITS

4-5-1 COMPOUNDER CIRCUIT (MAIN UNIT)

IC-F60/F61 have compounder circuit which can improve S/N ratio and become wide dynamic range to suppress the transmitting signal and to extend receiving signal. The circuit is composed of the base band IC (MAIN unit; IC10).

(1) IN CASE OF TRANSMITTING

The audio signals from the microphone are applied to the base band IC (IC10, pin 3) via microphone mute circuit (FRONT unit; IC406), microphone amplifier (IC407), etc. The signals are amplified at the amplifier section, and are then applied to the compressor circuit to compress the audio signals. The signals pass through (or bypass) scrambler section, and are then amplified at limiter amplifier section after being passed through the high-pass filter. The amplified signals pass through the low-pass filter section, and are then applied to the modulation circuit (Q13, D16–D18) via the FM/PM switch (IC11), low-pass filter (IC5) and D/A converter (IC6).

(2) IN CASE OF RECEIVING

The demodulated AF signals from the IF IC are applied to the amplifier section of base band IC (IC10, pin 23), and then pass through the low-pass and high-pass filter section to suppress unwanted signals. The filtered signals pass through (or bypass) scrambler section, and are then applied to the expander circuit to expand AF signals. The signals pass through (or bypass) scrambler IC (IC14), and are then applied to the analog switch (IC13, pins 8, 11). The signals are applied to the base band IC's amplifier section (IC10, pins 19, 20), and are then applied to the AF amplifier circuit.

4-6 PORT ALLOCATIONS

4-6-1 EXPANDER IC (FRONT UNIT; IC410)

Pin number	Port name	Description
4	LEDR	Outputs RX LED control signal. Low: Lights ON.
5	LEDT	Outputs TX LED control signal. Low: Lights ON.
6	LIGT	Outputs back light LED control signal. Low: Back light is ON.
7	AFON	Outputs audio control signal. Low: Outputs audio signals from speaker.
11	DUSE	<ul style="list-style-type: none"> Outputs CTCSS/DTCS switching signal when transmitting. High: Selected DTCS. Outputs Min. VR switching signal when receiving. Low: Select Min VR. <p>NOTE: Audio signals are prior to transmitting.</p>
12	MCON	Outputs microphone select signal. High: While the internal microphone is used.
13	CSFT	Outputs shift signal for reference oscillator's frequency.
14	SPON	Outputs the internal speaker control signal. High: The internal speaker is selected.

• BASE BAND IC BLOCK DIAGRAM

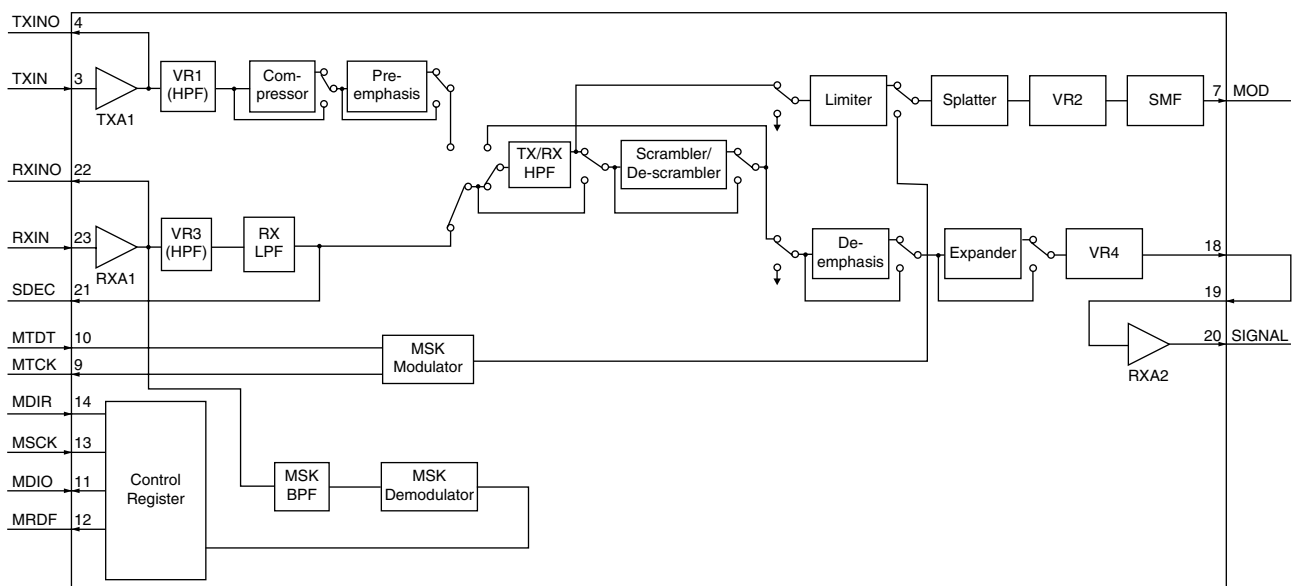

4-6-2 CPU (FRONT unit; IC401)

Pin number	Port name	Description
1–11, 13, 15–25,	SEG23–SEG13, SEG12, SEG11–SEG1	Output segment data to the LCD display.
26	SO	Outputs serial data to the PLL IC (MAIN unit; IC4, pin 10) and D/A convertor (MAIN unit; IC6, pin 8).
27	SCK	Outputs serial clock signal to the PLL IC (MAIN unit; IC4, pin 9), D/A convertor (MAIN unit; IC6, pin 7), etc.
28	MDIO	I/O port for the serial data signals from/to the base band IC (MAIN unit; IC10, pin 11).
29	MSCK	Outputs clock signal to the base band IC (MAIN unit; IC10, pin 13).
30	SCST	Outputs strobe signals to the scrambler IC (MAIN unit; IC14, pin 11).
31	PLST	Outputs strobe signals to the PLL IC (MAIN unit; IC4, pin 11).
32	ESDA	I/O port for data signals from/to the EEPROM (IC409, pin 5).
33	ESCL	Outputs clock signal to the EEPROM (IC409, pin 6).
34	SCAT	<ul style="list-style-type: none"> • Outputs power down control signal to the scrambler IC (MAIN unit; IC14, pin 12). • Input port for the detection signal whether the scrambler unit is installed or not.
35	EXSF	Outputs strobe signals to the expander IC (IC410, pin 2).
36	EXSM	Outputs strobe signals to the expander IC (MAIN unit; IC12, pin 1).
37	EXOE	Outputs the enable signal to the expander ICs (IC410, pin 15 and MAIN unit; IC12, pin 15).
38	BEEP	Outputs beep audio signals.
39	MTDT	Outputs MSK data for transmitting to the base band IC (MAIN unit; IC10, pin 10).
40	MTCK	Input port for the transmitting MSK clock signal from the base band IC (MAIN unit; IC10, pin 9).
41	NOIS	Input port for the noise signal from the FM IF IC (MAIN unit; IC1, pin 13).
43	SDEC	Input port for single tone decode signal from the base band IC (MAIN unit; IC10, pin 21).
44	CDEC	Input port for CTCSS/DTCS signal from the amplifier (MAIN unit; IC5, pin 8).

Pin number	Port name	Description
45	PTT	Input port for the PTT switch detection signal. Low: While the PTT switch is pushed.
46 47	KR1 KR0	Input ports for the key return A/D signals.
48	BATV	Input port for the detect signal for connecting battery pack's voltage.
49	LVIN	Input port for the PLL lock voltage.
50	RSSI	Input port for the S-meter signal from the FM IF IC (MAIN unit; IC1, pin 12).
51	TEMP	Input port for the transceiver's internal temperature detecting signal.
52	OPTV	Input port for the optional microphone determine signal.
55	ULCK	Input port for the PLL unlock signal. Low: The PLL circuit is unlocked.
71	MDIR	Outputs serial data control signal to the base band IC (MAIN unit; IC10, pin 14)
72–75	SENC3–SENC0	Output single tone encoder signal.
76	CLO	Outputs the cloning data signal.
77	CLI	Input port for the cloning data signal.
78	MRDF	Input port for the receiving MSK detection signal from the base band IC (MAIN unit; IC10, pin 12)
79–81	CENC2–CENC0	Output the CTCSS/DTCS signals.
82	DAST	<ul style="list-style-type: none"> • Outputs strobe signals to the D/A convertor (MAIN unit; IC6, pin 6). • Input port for the connecting battery type detect signal.
88–91	COM4–COM1	Output common signal to the LCD display.

4-6-3 EXPANDER IC (FRONT UNIT; IC410)

Pin number	Port name	Description
4	LEDR	Outputs RX LED control signal. Low: Lights ON.
5	LEDT	Outputs TX LED control signal. Low: Lights ON.
6	LIGT	Outputs back light LED control signal. Low: Back light is ON.
7	AFON	Outputs audio control signal. Low: Outputs audio signals from speaker.
11	DUSE	<ul style="list-style-type: none"> Outputs CTCSS/DTCS switching signal when transmitting. High: Selected DTCS. Outputs Min. VR switching signal when receiving. Low: Select Min VR. <p>NOTE: Audio signals are prior to transmitting.</p>
12	MCON	Outputs microphone select signal. High: While the internal microphone is used.
13	CSFT	Outputs shift signal for reference oscillator's frequency.
14	SPON	Outputs the internal speaker control signal. High: The internal speaker is selected.

4-6-5 EXPANDER IC (MAIN UNIT; IC12)

Pin number	Port name	Description
4	R5C	Outputs the R5 regulator (Q22) control signal. Low: While receiving.
5	T5C	Outputs the T5 regulator (Q21) control signal. Low: While transmitting.
7	S5C	Outputs the S5 regulator (Q23–Q25) control signal. Low: While the S5 regulator outputs 5 V voltage.
11	MUT2	Outputs the analog switch (IC13, pins 5, 6) control signal to control the scrambler unit. High: While the scrambler function is ON. Low: While the microphone mute or AF mute is ON.
12	MUT1	Outputs the analog switch (IC13, pins 12, 13) control signal to control the scrambler unit. High: While the scrambler function is ON. Low: While the microphone mute or AF mute is ON.
13	PMFM	Outputs the FM/PM modulation switching signal to the FM/PM switch (IC11, pin 5). High: PM is selected.
14	TMUT	Outputs the transmitting mute switch control signal to the mute switch (D38). High: While muting.

4-6-4 D/A CONVERTER IC (MAIN UNIT; IC6)

Pin number	Port name	Description
11	BAL	Outputs the modulation balance level control signal. The signal is applied to the buffer amplifier (IC5, pin 13).
14	T2	<ul style="list-style-type: none"> Outputs the bandpass filter tuning signal. The output signal is applied to the bandpass filters (D9, D10). Outputs the TX power control signal. The output signal is applied to the APC amplifier (IC2, pin 1).
15	T1	Outputs the bandpass filter tuning signal. The output signal is applied to the bandpass filters (D3, D4, D7, D8).
22	LVA	Outputs the PLL lock voltage control signal.
23	REF	Outputs the reference oscillator correcting voltage. The voltage is applied to the buffer amplifier (IC5, pin 12).

SECTION 5 ADJUSTMENT PROCEDURES

5-1 PREPARATION

When adjusting IC-F60/F61, the optional CS-F50 ADJ ADJUSTMENT SOFTWARE (Rev. 1.0 or later), *OPC-966 JIG CABLE (modified OPC-966 CLONING CABLE) are required.

■ REQUIRED TEST EQUIPMENT

EQUIPMENT	GRADE AND RANGE	EQUIPMENT	GRADE AND RANGE
DC power supply	Output voltage : 7.2 V DC Current capacity : 3 A or more	Audio generator	Frequency range : 300–3000 Hz Output level : 1–500 mV
FM deviation meter	Frequency range : DC–600 MHz Measuring range : 0 to ±10 kHz	Attenuator	Power attenuation : 40 or 50 dB Capacity : 10 W or more
Frequency counter	Frequency range : 0.1–600 MHz Frequency accuracy : ±1 ppm or better Sensitivity : 100 mV or better	Standard signal generator (SSG)	Frequency range : 300–600 MHz Output level : 0.1 μV to 32 mV (–127 to –17 dBm)
Digital multimeter	Input impedance : 10 MΩ/V DC or more	DC voltmeter	Input impedance : 50 kΩ/V DC or more
RF power meter (terminated type)	Measuring range : 1–10 W Frequency range : 300–600 MHz Impedance : 50 Ω SWR : Less than 1.2 : 1	Oscilloscope	Frequency range : DC–20 MHz Measuring range : 0.01–20 V
		AC millivoltmeter	Measuring range : 10 mV to 10 V

■ SYSTEM REQUIREMENTS

- Microsoft® Windows® 95/98/ME
- RS-232C serial port (DB9)

■ ADJUSTMENT SOFTWARE INSTALLATION

- ① Boot up Windows.
- Quit all applications when Windows is running.
- ② Insert the cloning software CD-ROM into the appropriate CD-ROM drive.
- ③ Select 'Run' from the [Start] menu.
- ④ Type the setup program name using the full path name, then push [Enter] key.
(For example; D:\Setup.exe)
- ⑤ Follow the prompts.
- ⑥ Program group 'CS-F50 ADJ' appears in the 'Programs' folder of the [Start] menu.

■ BEFORE STARTING SOFTWARE ADJUSTMENT

Clone the adjustment frequencies, listed in page 5-2, into the transceiver using with the CS-F50 before starting the software adjustment. Otherwise, the transceiver can not start software adjustment.

CAUTION!: BACK UP the originally programmed memory data in the transceiver before programming the adjustment frequencies.
When program the adjustment frequencies into the transceiver, the transceiver's memory data will be overwritten and lose original memory data at the same time.

■ STARTING SOFTWARE ADJUSTMENT

- ① Connect IC-F60/F61 and PC with *OPC-966 JIG CABLE.
- ② Turn the transceiver power ON.
- ③ Boot up Windows, and click the program group 'CS-F50 ADJ' in the 'Programs' folder of the [Start] menu, then CS-F50 ADJ's window appears.
- ④ Click 'Connect' on the CS-F50's window, then appears IC-F60/F61's up-to-date condition.
- ⑤ Set or modify adjustment data as desired.

Microsoft and Windows are registered trademarks of Microsoft Corporation in the U.S.A. and other countries.

• PC SCREEN EXAMPLE

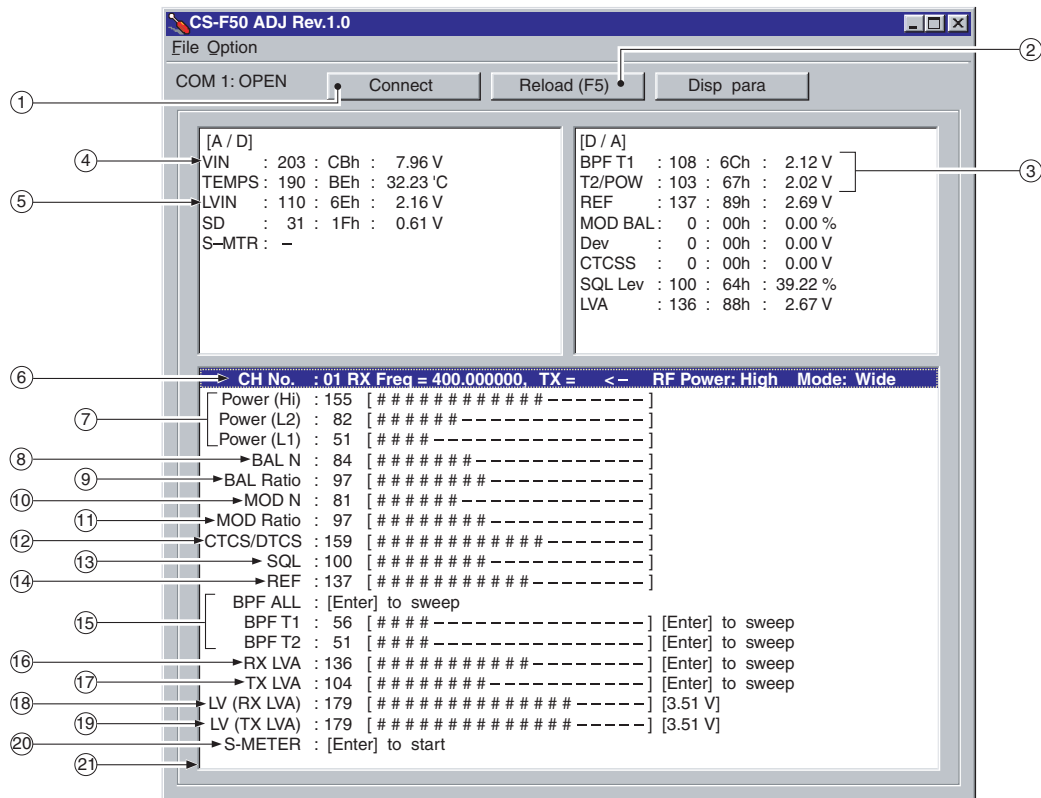

NOTE: The above values for settings are example only.
Each transceiver has its own specific values for each setting.

- ① : Transceiver's connection state
- ② : Reload adjustment data
- ③ : Receive sensitivity measurement
- ④ : Connected DC voltage measurement
- ⑤ : PLL lock voltage measurement
- ⑥ : Operating channel select
- ⑦ : RF output power
- ⑧ : FM deviation balance (Narrow)
- ⑨ : FM deviation balance (Wide)
- ⑩ : FM deviation (Narrow)
- ⑪ : FM deviation (Wide/Middle)
- ⑫ : CTCSS/DTCS deviation
- ⑬ : Squelch level
- ⑭ : Reference frequency
- ⑮ : Receive sensitivity (automatically)
- ⑯ : PLL lock voltage for RX (automatically)
- ⑰ : PLL lock voltage for TX (automatically)
- ⑱ : PLL lock voltage for RX (manually)
- ⑲ : PLL lock voltage for TX (manually)
- ⑳ : S-meter
- ㉑ : Adjustment items

• ADJUSTMENT FREQUENCY LIST

CH	FREQUENCY		ADJUSTMENT ITEM	CH	FREQUENCY		ADJUSTMENT ITEM
	LOW BAND	HIGH BAND			LOW BAND	HIGH BAND	
1	400.000 MHz	450.000 MHz	TX power : Hi	8	435.000 MHz	485.000 MHz	TX power : L1
2	400.000 MHz	450.000 MHz	TX power : L2				DTCS code : 007
3	400.000 MHz	450.000 MHz	TX power : L1 Band width : Wide				Band width : Middle
4	435.000 MHz	485.000 MHz	TX power : L1 Band width : Middle	9	435.000 MHz	485.000 MHz	TX power : L1 DTCS code : 007 Band width : Wide
5	435.000 MHz	485.000 MHz	TX power : L1 Band width : Middle	10	435.000 MHz	485.000 MHz	TX power : L1
6	435.000 MHz	485.000 MHz	TX power : L1 Band width : Wide				CTCSS : 151.4 Hz DTCS code : 007 Band width : Wide
7	435.000 MHz	485.000 MHz	TX power : L1	11	470.000 MHz	452.000 MHz	TX power : L1 Band width : Wide
			DTCS code : 007 Band width : Narrow	12	400.000 MHz	485.000 MHz	TX power : L1 Band width : Wide

• CONNECTION

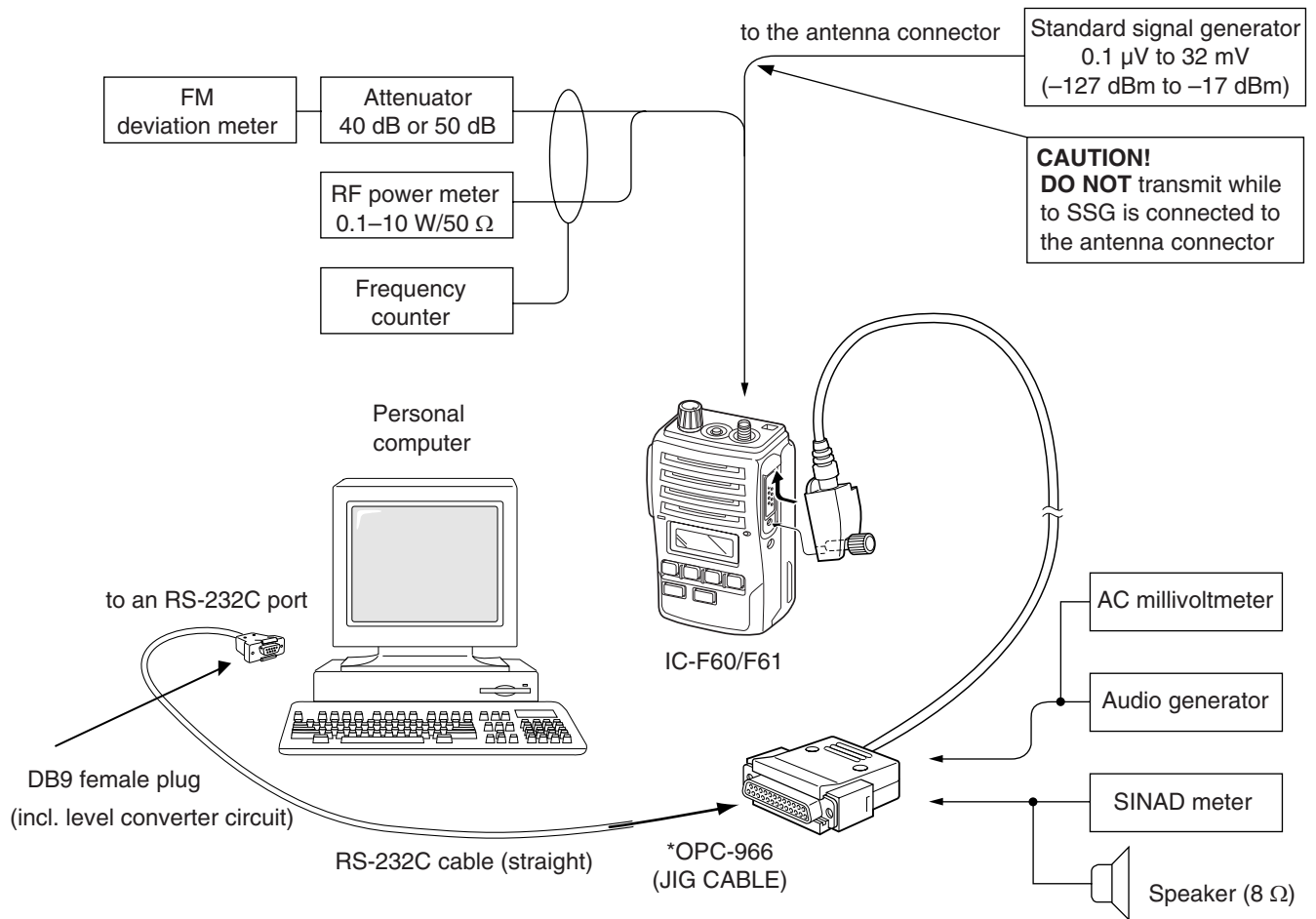

• *OPC-966 (JIG CABLE)

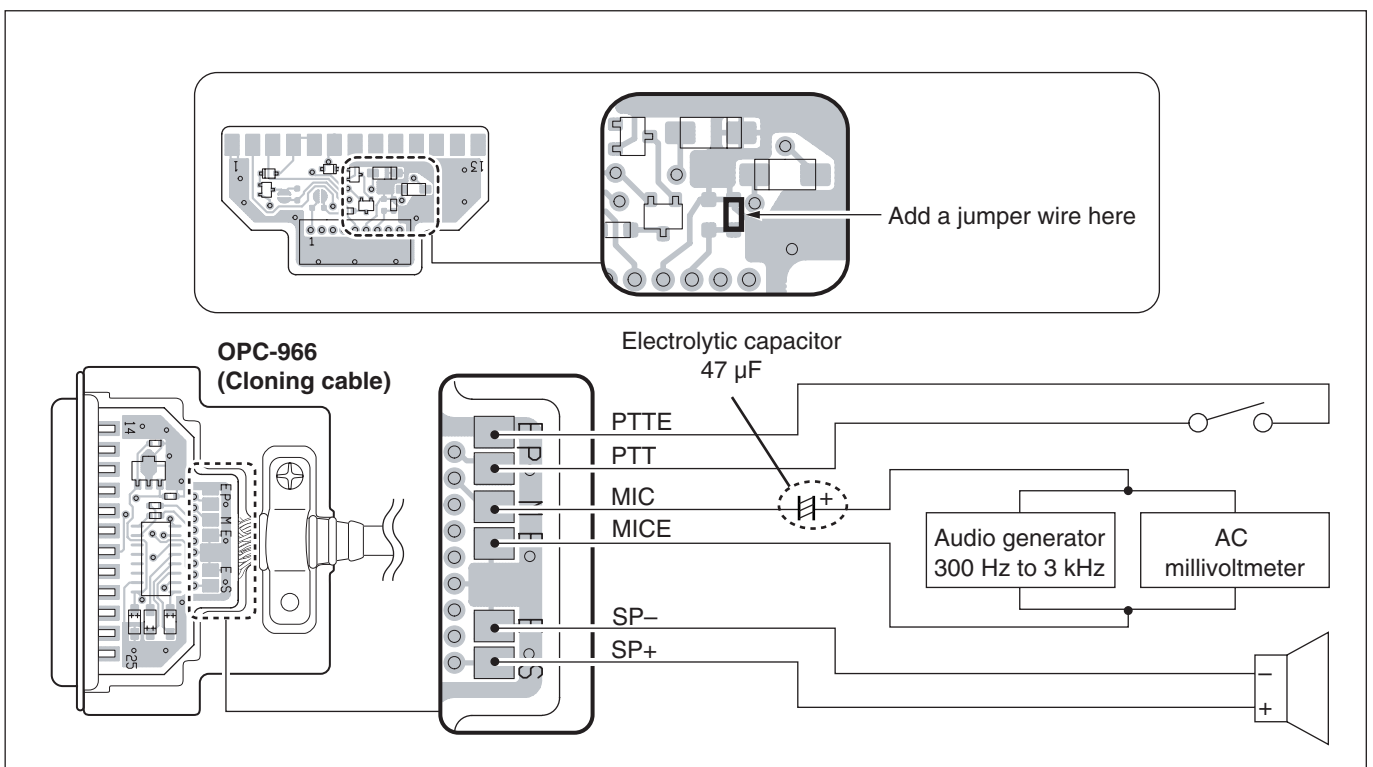

5-2 SOFTWARE ADJUSTMENT (TRANSMITTING)

Select an operation using [↑] / [↓] keys, then set specified value using [←] / [→] keys on the connected computer keyboard.

ADJUSTMENT	ADJUSTMENT CONDITION	MEASUREMENT		VALUE
		UNIT	LOCATION	
PLL LOCK VOLTAGE [LV (RX LVA)] [LV (TX LVA)]	1 • Operating CH : CH3 • Receiving	MAIN	Check the “LV” item on the CS-F50 ADJ’s screen.	1.0 V
	2 • Operating CH : CH3 • Transmitting		Check the “TX LV” item on the CS-F50 ADJ’s screen.	1.0 V
	3 • Operating CH : CH11 • Receiving	MAIN	Check the “LV” item on the CS-F50 ADJ’s screen.	3.3–4.5 V (Verify)
	4 • Operating CH : CH11 • Transmitting		Check the “TX LV” item on the CS-F50 ADJ’s screen.	3.3–4.5 V (Verify)
	1 • Operating CH : CH11 • Output power : Low1 • Connect an RF power meter or 50 Ω dummy load to the antenna connector. • Transmitting	Top panel	Loosely couple a frequency counter to the antenna connector.	470.0000 MHz [L] 520.0000 MHz [H] ±300 Hz
OUTPUT POWER [Power (Hi)]	1 • Operating CH : CH1 • Transmitting	Top panel	Connect an RF power meter to the antenna connector.	4.0 W
[Power (L2)]	2 • Operating CH : CH2 • Transmitting			2.0 W
[Power (L1)]	3 • Operating CH : CH3 • Transmitting			1.0 W
FM DEVIATION [MOD N] (Narrow)	1 • Operating CH : CH4 • Set the FM deviation meter as: HPF : OFF LPF : 20 kHz De-emphasis : OFF Detector : (P–P)/2 • Connect the audio generator to the multi connector through the JIG cable (*OPC-966) and set as: : 1.0 kHz/150 mVrms • Transmitting	Top panel	Connect an FM deviation meter to the antenna connector through the attenuator.	±2.05 to ±2.15 kHz
[MOD Ratio] (Middle)	2 • Operating CH : CH5 • Transmitting			±3.15 to ±3.25 kHz
[MOD Ratio] (Wide)	3 • Operating CH : CH6 • Transmitting			±4.05 to ±4.15 kHz

SOFTWARE ADJUSTMENT (TRANSMITTING) – continued

Select an operation using [↑] / [↓] keys, then set specified value using [←] / [→] keys on the connected computer keyboard.

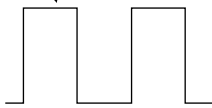
ADJUSTMENT	ADJUSTMENT CONDITION	MEASUREMENT		VALUE
		UNIT	LOCATION	
MODULATION BALANCE [BAL N] (Narrow)	1 <ul style="list-style-type: none"> • Operating CH : CH7 • No audio applied to the multi connector. • Set an FM deviation meter as: <ul style="list-style-type: none"> HPF : OFF LPF : 20 kHz De-emphasis : OFF Detector : (P-P)/2 • IF bandwidth : Narrow • Transmitting 	Top panel	Connect an FM deviation meter with an oscilloscope to the antenna connector through an attenuator.	Set to square wave form 
[BAL Ratio] (Middle)	2 <ul style="list-style-type: none"> • Operating CH : CH8 • Transmitting 			
[BAL Ratio] (Wide)	3 <ul style="list-style-type: none"> • Operating CH : CH9 • Transmitting 	Top panel	Connect an FM deviation meter to the antenna connector through the attenuator.	±0.66 to ±0.70 kHz
CTCSS/DTCS DEVIATION [CTCS/DTCS]	<ul style="list-style-type: none"> • Operating CH : CH10 • No audio applied to the multi connector. • Transmitting 			

5-3 SOFTWARE ADJUSTMENT (RECEIVING)

- Select an operation using [↑] / [↓] keys, then set specified value using [←] / [→] keys on the connected computer keyboard.
- Need to adjust “S-METER ADJUSTMENT” after “RX SENSITIVITY ADJUSTMENT” is adjusted. Otherwise, “S-METER ADJUSTMENT” will not be adjusted properly.

ADJUSTMENT	ADJUSTMENT CONDITION	MEASUREMENT		VALUE	
		UNIT	LOCATION		
RX SENSITIVITY [BPF T1], [BPF T2]	1	<ul style="list-style-type: none"> • Operating CH : CH3 • Connect a standard signal generator to the antenna connector and set as: <ul style="list-style-type: none"> Frequency : 400.000 MHz [L] 485.000 MHz [H] Level : 10 μV* (-87 dBm) Modulation : 1 kHz Deviation : ±3.5 kHz • Receiving 	MAIN	Connect a SINAD meter with an 8 Ω load to the multi connector through the JIG cable (*OPC-966).	Minimum distortion level
	<p>CONVENIENT: The BPF T1, BPF T2 can be adjusted automatically.</p> <p>①-1: Set the cursor to “BPF ALL” on the adjustment program and then push [ENTER] key. ①-2: The connected PC tunes BPF T1, BPF T2 to peak levels. or ②-1: Set the cursor to one of BPF T1, T2 as desired. ②-2: Push [ENTER] key to start tuning. ②-3: Repeat ②-1 and ②-2 to perform additional BPF tuning.</p>				
S-METER [S-METER]	1	<ul style="list-style-type: none"> • Operating CH : CH3 • Connect an SSG to the antenna connector and set as: <ul style="list-style-type: none"> Frequency : 400.000 MHz [L] 485.000 MHz [H] Level : 4.5 μV* (-94 dBm) Modulation : 1 kHz Deviation : ±3.5 kHz • Receiving 	Push the [ENTER] key on the connected computer’s keyboard to set “S6 level”.		
	2	<ul style="list-style-type: none"> • Set an SSG as : <ul style="list-style-type: none"> Level : 0.25 μV* (-119 dBm) Modulation : 1 kHz Deviation : ±3.5 kHz • Receiving 	Push the [ENTER] key on the connected computer keyboard to set “S1 level”.		
SQUELCH LEVEL [SQL]	1	<ul style="list-style-type: none"> • Operating CH : CH11 • Connect an SSG to the antenna connector and set as: <ul style="list-style-type: none"> Frequency : 470.000 MHz [L] 520.000 MHz [H] Level : 0.2 μV* (-121 dBm) Modulation : 1 kHz Deviation : ±3.5 kHz • Receiving 	Front panel	Internal speaker	Set “SQL level” to close squelch. Then set “SQL level” at the point where the audio signals just appears.

*The output level of the standard signal generator (SSG) is indicated as the SSG’s open circuit.

[MAIN UNIT]

REF NO.	ORDER NO.	DESCRIPTION	M.	H/V LOCATION
C115	4030017570	S.CER ECJ0EC1H040B	B	40.9/24.2
C116	4030017460	S.CER ECJ0EB1E102K	B	40.9/25.2
C117	4030017730	S.CER ECJ0EB1E471K	B	41.6/26.2
C118	4030017530	S.CER ECJ0EC1H0R5B	B	43.7/27.2
C119	4030016790	S.CER ECJ0EB1C103K	B	41.6/27.2
C120	4030017730	S.CER ECJ0EB1E471K	B	40.6/28.6
C121	4030017380	S.CER ECJ0EC1H050B	B	42.1/31
C120	4030017570	S.CER ECJ0EC1H040B	B	43.2/32.3
C123	4030017640	S.CER ECJ0EC1H150J	B	40.9/32
C124	4030017380	S.CER ECJ0EC1H050B	B	39.6/32.3
C126	4030017640	S.CER ECJ0EC1H150J	B	40.9/21.4
C127	4030017580	S.CER ECJ0EC1H060C	B	39.6/21.1
C129	4030017530	S.CER ECJ0EC1H0R5B	B	38.3/23.8
C130	4030016950	S.CER ECJ0EB1A473K	T	31.6/23.6
C132	4030017460	S.CER ECJ0EB1E102K	T	31.4/19.3
C133	4030017630	S.CER ECJ0EC1H120J	B	39.6/30.5
C134	4030017630	S.CER ECJ0EC1H120J	B	39.6/22.9
C135	4030017460	S.CER ECJ0EB1E102K	B	36.7/28.6
C136	4030016930	S.CER ECJ0EB1A104K	B	36.7/29.6
C137	4030016790	S.CER ECJ0EB1C103K	B	44.1/36.9
C138	4030017460	S.CER ECJ0EB1E102K	T	37.1/29
C139	4030016930	S.CER ECJ0EB1A104K	T	46.3/34.2
C140	4030016930	S.CER ECJ0EB1A104K	B	28.5/28.4
C141	4030017460	S.CER ECJ0EB1E102K	B	32.7/20.6
C143	4030017460	S.CER ECJ0EB1E102K	T	32.1/21.3
C144	4030017420	S.CER ECJ0EC1H470J	T	36.8/27.3
C145	4030017420	S.CER ECJ0EC1H470J	T	36.2/22.9
C146	4550000550	S.TAN TEESVA 1E 224M8L	T	35.2/30.3
C147	4550000460	S.TAN TEESVA 1C 105M8L	T	30/25.9
C148	4550006250	S.TAN TEESVA 1A 106M8L	B	43/40.3
C149	4030017460	S.CER ECJ0EB1E102K	T	28.4/28.5
C150	4030017490	S.CER C1608 JB 1A 105K-T	T	30.2/16.8
C151	4030016930	S.CER ECJ0EB1A104K	B	28.9/30
C152	4030017420	S.CER ECJ0EC1H470J	B	31.7/16.9
C153	4030017420	S.CER ECJ0EC1H470J	B	30.7/16.9
C154	4030017420	S.CER ECJ0EC1H470J	B	29.7/18.5
C155	4030017420	S.CER ECJ0EC1H470J	T	28.4/31.5
C156	4030017460	S.CER ECJ0EB1E102K	B	25.3/27.5
C157	4030017620	S.CER ECJ0EC1H100C	B	25.7/29
C158	4030016930	S.CER ECJ0EB1A104K	B	24.8/35.2
C159	4030017460	S.CER ECJ0EB1E102K	B	24.8/31
C161	4030017620	S.CER ECJ0EC1H100C	B	25.3/23.8
C162	4030017500	S.CER ECJ0EC1H560J	B	29.2/17.2
C163	4030017570	S.CER ECJ0EC1H040B	B	27.5/15.8
C164	4030017590	S.CER ECJ0EC1H070C	B	26.2/14.5
C165	4030016790	S.CER ECJ0EB1C103K	B	28.7/18.5
C166	4030017360	S.CER ECJ0EC1H030B	B	27.5/14
C167	4030016930	S.CER ECJ0EB1A104K	B	6.4/6.3
C168	4030016930	S.CER ECJ0EB1A104K	B	8.8/5.5
C169	4030016930	S.CER ECJ0EB1A104K	B	8.8/8.1
C170	4030016930	S.CER ECJ0EB1A104K	T	25.7/4.9
C171	4030018560	S.CER C2012 JB 1A 475K-T	T	24.4/3.2
C172	4030017460	S.CER ECJ0EB1E102K	T	26.5/3.1
C173	4030017460	S.CER ECJ0EB1E102K	T	28.2/18.3
C180	4030016930	S.CER ECJ0EB1A104K	B	26.7/10.5
C188	4030017460	S.CER ECJ0EB1E102K	B	17.9/6.6
C201	4030017490	S.CER ECJ0EB1A105K	B	36.9/27.6
C202	4030016930	S.CER ECJ0EB1A104K	B	36.9/27.6
C203	4030017460	S.CER ECJ0EB1E102K	B	39.8/27.3
C205	4030017380	S.CER ECJ0EC1H050B	T	44.1/32.8
C206	4030017590	S.CER ECJ0EC1H070C	T	40.8/33.3
C208	4030017590	S.CER ECJ0EC1H070C	T	36.2/33.8
C209	4030017460	S.CER ECJ0EB1E102K	T	35.2/33.8
C211	4030018560	S.CER C2012 JB 1A 475K-T	B	16.5/4
C220	4030016970	S.CER ECJ0EB1C223K	B	5.3/24.2
C224	4550000460	S.TAN TEESVA 1C 105M8L	B	30.6/14.6
C227	4030016790	S.CER ECJ0EB1C103K	B	23.3/12.9
C228	4030017460	S.CER ECJ0EB1E102K	B	18.4/13.9
C229	4030016930	S.CER ECJ0EB1A104K	T	24.7/10.3
C230	4030017460	S.CER ECJ0EB1E102K	T	67.4/28.3
C231	4030016790	S.CER ECJ0EB1C103K	B	52.4/34.7
C232	4030016790	S.CER ECJ0EB1C103K	B	32.7/40.2
C233	4550006350	S.TAN TEESVB2 1A 226M8L	B	67.1/27.2
C234	4030017730	S.CER ECJ0EF1C471Z	B	69.6/29.8
C235	4030016790	S.CER ECJ0EB1C103K	B	66.9/31
C236	4510004630	S.ELE ECEV1CA100SR	T	72.5/20.4
C237	4030016790	S.CER ECJ0EB1C103K	T	75.9/29.1
C238	4550006480	S.TAN TEESVA 1C 475M8L	B	66.5/35.1
C239	4030017330	S.CER ECJ0EF1C104Z	T	71.5/29
C240	4030017460	S.CER ECJ0EB1E102K	B	29.6/11
C241	4030017460	S.CER ECJ0EB1E102K	T	51.6/37.6
C242	4030017460	S.CER ECJ0EB1E102K	B	34.6/36
C243	4030017420	S.CER ECJ0EC1H470J	B	53.5/41.5
C244	4030017420	S.CER ECJ0EC1H470J	B	22.2/20.2
C251	4030017420	S.CER ECJ0EC1H470J	T	24.8/17.5
C252	4030017910	S.CER ECJ0EB1H152K	T	26.5/31.2
C253	4030017710	S.CER ECJ0EC1H181J	T	14/16.7
C254	4030017750	S.CER ECJ0EB1E122K	T	14.8/14.6
C255	4030016930	S.CER ECJ0EB1A104K	B	17.4/12.1
C256	4030017760	S.CER ECJ0EB1H222K	T	13/18.5
C257	4030016930	S.CER ECJ0EB1A104K	T	20.8/26.6
C258	4030016930	S.CER ECJ0EB1A104K	T	21.8/26.6
C259	4030017400	S.CER ECJ0EC1H220J	B	9/23.1
C260	4030017400	S.CER ECJ0EC1H220J	B	22.1/23.1

[MAIN UNIT]

REF NO.	ORDER NO.	DESCRIPTION	M.	H/V LOCATION
C261	4550000460	S.TAN TEESVA 1C 105M8L	B	20.8/17.6
C262	4550000460	S.TAN TEESVA 1C 105M8L	B	20.8/15.5
C263	4030017460	S.CER ECJ0EB1E102K	T	13/21.1
C264	4550006350	S.TAN TEESVB2 1A 226M8L	B	14.2/17.1
C265	4030017460	S.CER ECJ0EB1E102K	T	26.1/21.9
C266	4030017720	S.CER ECJ0EB1H331K	T	24.6/20.6
C267	4030017460	S.CER ECJ0EB1E102K	B	22/12.9
C271	4030016930	S.CER ECJ0EB1A104K	T	26/33.5
C273	4030016930	S.CER ECJ0EB1A104K	B	16.5/37.2
C274	4030016930	S.CER ECJ0EB1A104K	B	17.1/26.7
C275	4030017490	S.CER C1608 JB 1A 105K-T	B	6.9/41.6
C276	4030017490	S.CER C1608 JB 1A 105K-T]	B	11.1/41.6
C277	4030017490	S.CER C1608 JB 1A 105K-T	B	14.2/39.9
C279	4030017650	S.CER ECJ0EC1H270J]	B	29.1/41.4
C280	4030017650	S.CER ECJ0EC1H270J	B	16.5/41.4
C281	4030016930	S.CER ECJ0EB1A104K	T	13.6/34.3
C287	4030016930	S.CER ECJ0EB1A104K	B	32.7/31.8
C288	4030016930	S.CER ECJ0EB1A104K]	B	20.3/31.3
C289	4030016930	S.CER ECJ0EB1A104K]	B	19.3/32.6
C290	4030016930	S.CER ECJ0EB1A104K]	T	25.4/28.7
C291	4030017420	S.CER ECJ0EC1H470J	B	56.1/11.9
C292	4030017460	S.CER ECJ0EB1E102K	B	54.7/8.1
C293	4030017460	S.CER ECJ0EB1E102K	T	77.4/24.4
C294	4030017460	S.CER ECJ0EB1E102K	B	4.7/26.2
C295	4030017460	S.CER ECJ0EB1E102K	T	71.5/24.7
C296	4030017460	S.CER ECJ0EB1E102K	T	77.4/23.4
C297	4030017460	S.CER ECJ0EB1E102K	T	75.9/21
C298	4030017460	S.CER ECJ0EB1E102K	T	2.8/31.8
C299	4030017460	S.CER ECJ0EB1E102K	T	2.8/32.8
C300	4030017460	S.CER ECJ0EB1E102K	T	2.8/33.8
C301	4030017460	S.CER ECJ0EB1E102K	T	2.8/30.5
C302	4030017620	S.CER ECJ0EC1H100C	B	48.6/14.3
C303	4030017460	S.CER ECJ0EB1E102K	B	50.9/13
C304	4030016930	S.CER ECJ0EB1A104K	T	18.7/37.4
C305	4030016930	S.CER ECJ0EB1A104K	T	24.4/37.5
C333	4030017420	S.CER ECJ0EC1H470J	T	46.9/5.4
C339	4030017520	S.CER ECJ0EC1H0R3B	T	45.4/6.8
C363	4030017580	S.CER ECJ0EC1H060C	B	47.3/13.8
C364	4030017580	S.CER ECJ0EC1H060C	B	46/11.2
C365	4030009520	S.CER C1608 CH 1H 020B-T	B	69.3/5.8
C366	4030017460	S.CER ECJ0EB1E102K	T	65.8/27.6
C367	4030009910	S.CER C1608 CH 1H 040B-T	B	58.5/4.8
C368	4030017420	S.CER ECJ0EC1H470J	T	66.3/28.9
C369	4030006860	S.CER C1608 JB 1H 102K-T	T	55.3/18.7
C370	4030017460	S.CER ECJ0EB1E102K	B	51.7/26.2
C371	4030017460	S.CER ECJ0EB1E102K	T	62.1/10.8
C372	4030017590	S.CER ECJ0EC1H070C	B	53.5/26.2
C373	4030017460	S.CER ECJ0EB1E102K	T	52.6/30.1
C374	4550006650	S.TAN ECST1CY685R	B	52.6/15.7
C375	4550006250	S.TAN TEESVA 1A 106M8L	T	49.7/33.5
J1	6510023520	S.CNR 54104-3692	T	7.4/25.2
F1	5210000900	S.FUS 0434003.NRP		
S1	2260002750	S.SW EVQP7M01K		
EP1	6910015370	S.BEA ACZ1005Y-102-T		
EP3	6910015370	S.BEA ACZ1005Y-102-T		
EP4	6910015600	S.BEA ACZ1005Y-241		
EP5	6910015600	S.BEA ACZ1005Y-241		

M.=Mounted side (T: Mounted on the Top side, B: Mounted on the Bottom side)

S.=Surface mount

[FRONT UNIT]

REF NO.	ORDER NO.	DESCRIPTION	M.	H/V LOCATION
C478	4030017460	S.CER ECJ0EB1E102K	T	13.7/36.4
C479	4030017460	S.CER ECJ0EB1E102K	T	19.2/16.5
C481	4030017460	S.CER ECJ0EB1E102K	T	4.4/35.6
C482	4030017460	S.CER ECJ0EB1E102K	T	11.5/37.7
C483	4030017460	S.CER ECJ0EB1E102K	T	38.1/43.4
C484	4030017460	S.CER ECJ0EB1E102K	B	14.7/55.2
C485	4030017460	S.CER ECJ0EB1E102K	B	7.3/58
C486	4030017460	S.CER ECJ0EB1E102K	T	10.1/56.5
C487	4030017460	S.CER ECJ0EB1E102K	T	34.3/36.9
C488	4030017460	S.CER ECJ0EB1E102K	T	23.9/43.7
C489	4030017460	S.CER ECJ0EB1E102K	T	8.5/27.1
C490	4030017460	S.CER ECJ0EB1E102K	T	41.2/28.6
C491	4030017460	S.CER ECJ0EB1E102K	T	37.3/38.8
C492	4030017460	S.CER ECJ0EB1E102K	T	8/22
C493	4030016930	S.CER ECJ0EB1A104K	T	16.9/34.7
C494	4030017460	S.CER ECJ0EB1E102K	T	39.6/67.3
C495	4030017460	S.CER ECJ0EB1E102K	T	9.4/39.8
C496	4550007060	S.TAN ECSTIAX336R	T	14.5/54.8
C497	4030016790	S.CER ECJ0EB1C103K	T	5.4/41.5
C498	4030017430	S.CER ECJ0EC1H101J	T	7.8/37.6
C499	4030017420	S.CER ECJ0EC1H470J	T	17.6/39.7
C500	4030016930	S.CER ECJ0EB1A104K	B	4.1/39
J401	6510023520	S.CNR 54104-3692	T	27.8/6.8
J402	6510023830	S.CNR SM04B-SRSS-TB	T	34.9/52.5
DS401	5030002730	LCD L3-0048TAY-5		
DS402	5040002420	S.LED SML-310MT T86	B	13.5/16.1
DS403	5040002420	S.LED SML-310MT T86	B	32.7/15.3
DS404	5040002960	S.LED SML-A12MT T86	B	6.4/38
DS405	5040002960	S.LED SML-A12MT T86	B	42.6/38
DS406	5040002670	S.LED CL-165HR/YG	B	45.3/50.2
MC401	7700002480	MIC SKB-2746 LPC		
S401	2260002840	SW SKHLLFA010		
SP401	2510001092	SP 036D0801B <FG>		
W401	8900011880	CBL OPC-1210 (P=0.5 N=36 L=70)		
W402	7120000470	JMP ERDS2T0		
W403	7120000470	JMP ERDS2T0		

[CONNECTOR UNIT]

REF NO.	ORDER NO.	DESCRIPTION	M.	H/V LOCATION
D701	1790001810	S.VSR AVR-M1005C080MTABB	B	8/2.4
D702	1790001810	S.VSR AVR-M1005C080MTABB	B	8/3.4
D703	1790001810	S.VSR AVR-M1005C080MTABB	B	8/4.4
D704	1790001810	S.VSR AVR-M1005C080MTABB	T	9.6/6.1
D705	1790001810	S.VSR AVR-M1005C080MTABB	B	9.7/18.9
R701	7410001130	S.ARY EXB28V102JX	T	8/4.8
C701	4030017460	S.CER ECJ0EB1E102K	B	9.7/9.4
C702	4030017460	S.CER ECJ0EB1E102K	B	9.7/12.2
C703	4030017460	S.CER ECJ0EB1E102K	B	9.7/15.3
C704	4030017460	S.CER ECJ0EB1E102K	B	7.9/19.7
EP701	6910012350	S.BEA MMZ1608Y 102BT	B	8.2/8.6
EP702	6910012350	S.BEA MMZ1608Y 102BT	B	8.2/11.6
EP703	6910012350	S.BEA MMZ1608Y 102BT	B	8.2/14.6
EP704	6910012350	S.BEA MMZ1608Y 102BT	B	8.5/17.2
EP705	6910012350	S.BEA MMZ1608Y 102BT	B	9.8/17.2

[VR UNIT]

REF NO.	ORDER NO.	DESCRIPTION	M.	H/V LOCATION
R601	7210003130	VAR TP76N97N-13F-10KA-2497		
W601	8900012340	CBL OPC-1260		

[CHASSIS UNIT]

REF NO.	ORDER NO.	DESCRIPTION	M.	H/V LOCATION
J1	6910015630	CNR 2682 ANT CONNECTOR		

M.=Mounted side (T: Mounted on the Top side, B: Mounted on the Bottom side)

S.=Surface mount

SECTION 7 MECHANICAL PARTS AND DISASSEMBLY

7-1 CABINET PARTS

[MAIN UNIT]

REF. NO.	ORDER NO.	DESCRIPTION	QTY.
MP4	8510016150	2682 shield plate	1
MP11	8930066530	Rubber sheet (BP)	1

[CHASSIS PARTS]

REF. NO.	ORDER NO.	DESCRIPTION	QTY.
J1	6910015630	2682 antenna connector	1
W1	7120000470	ERDS2T0	1
MP1	8010019290	2681 chassis	1
MP2	8950005511	2403 contact spring -1	1
MP3	8930058561	2403 A-main seal-1	1
MP4	8930059800	2600 pet sheet	1
MP5	8930059830	2600 sheet	1
MP6	8930051500	O ring (AB)	1
MP7	8930055870	O ring (AO)	1
MP8	8930058550	O ring (AS)	1
MP9	8830001600	Screw nut (L)	1
MP10	8830001470	VR nut (N)	1
MP11	8850001880	Sealing washer (W)	2
MP12	8810009510	Screw B0 2 × 4 NI-ZU (BT)	7
MP13	8810007890	Screw B0 2 × 4 SUS	1
MP14	8810010121	Screw B0 2 × 8 SUS SSBC	2
MP15	8810010190	Screw M2 × 4 SUS ZK	3
MP19	8930068750	Shield tape (R)	1

[FRONT UNIT]

REF. NO.	ORDER NO.	DESCRIPTION	QTY.
DS401	5030002630	L3-0048TAY-2	1
EP402	8930061530	SRCN-2681-SP-N-W	2
SP401	2510001092	036D0801B	1
W401	8900011880	OPC-1210A	1
MP401	8210019860	2681 front panel	1
MP404	8930060540	2681 4-2 Key board	1
MP405	8210019880	2681 PTT button	1
MP406	8930060550	2681 PTT plate	1
MP407	8930060710	2681 PTT rubber	1
MP408	8310059540	2681 LCD plate	1
MP410	8210019890	2681 Reflector	1
MP411	8310059530	2681 window plate	1
MP412	8930060860	2681 window sheet	1
MP413	8930059360	2600 release button	1
MP414	8930055761	2403 release plate	1
MP415	8930056540	Spring (AH)	2
MP417	8930055730	2403 connector seal	1
MP418	8930055890	2403 connector sheet	1
MP419	8930056430	2403 9-pin sheet	1
MP421	8610011380	Knob N-313	1
MP423	8930061110	2681 mic tape	1
MP424	8810009510	Screw B0 2 × 4 NI-ZU (BT)	4
MP426	8930061200	2681 mic rubber	1
MP429	8930062240	Sponge (HM)	1

[VR UNIT]

REF. NO.	ORDER NO.	DESCRIPTION	QTY.
R601	7210003130	TP76N97N-13F-10KA-2497	1

[CONNECTOR UNIT]

REF. NO.	ORDER NO.	DESCRIPTION	QTY.
MP701	8950005520	2403 9-pin connector	1

Screw abbreviations B0, BT: Self-tapping
 ZK: Black
 SUS: Stainless
 NI-ZU: Nickel-zinc

[ACCESSORIES]

REF. NO.	ORDER NO.	DESCRIPTION	QTY.
EP1	Optional Product	Battery BP-227AX	1
EP2	Optional Product	Antenna FA-S27U	1
MP1	Optional Product	Beltclip MB-98	1
MP2	8210017071	2337 C-Panel-1	1
MP3	8810009270	Screw M3 × 4 SUS SSBC	1
MP4	8310060530	2681 key-sticker	1

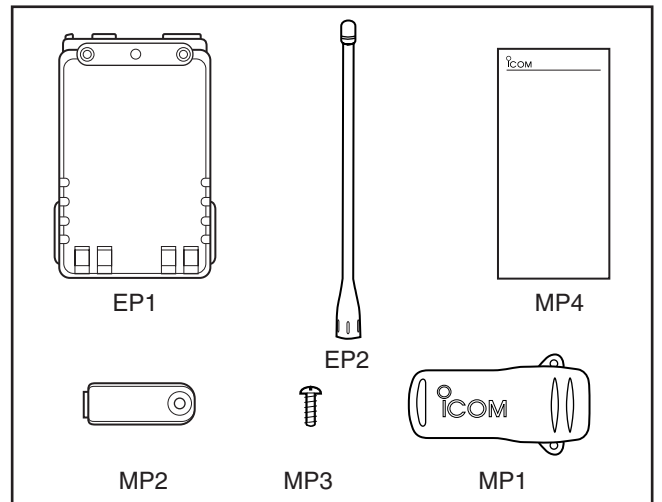

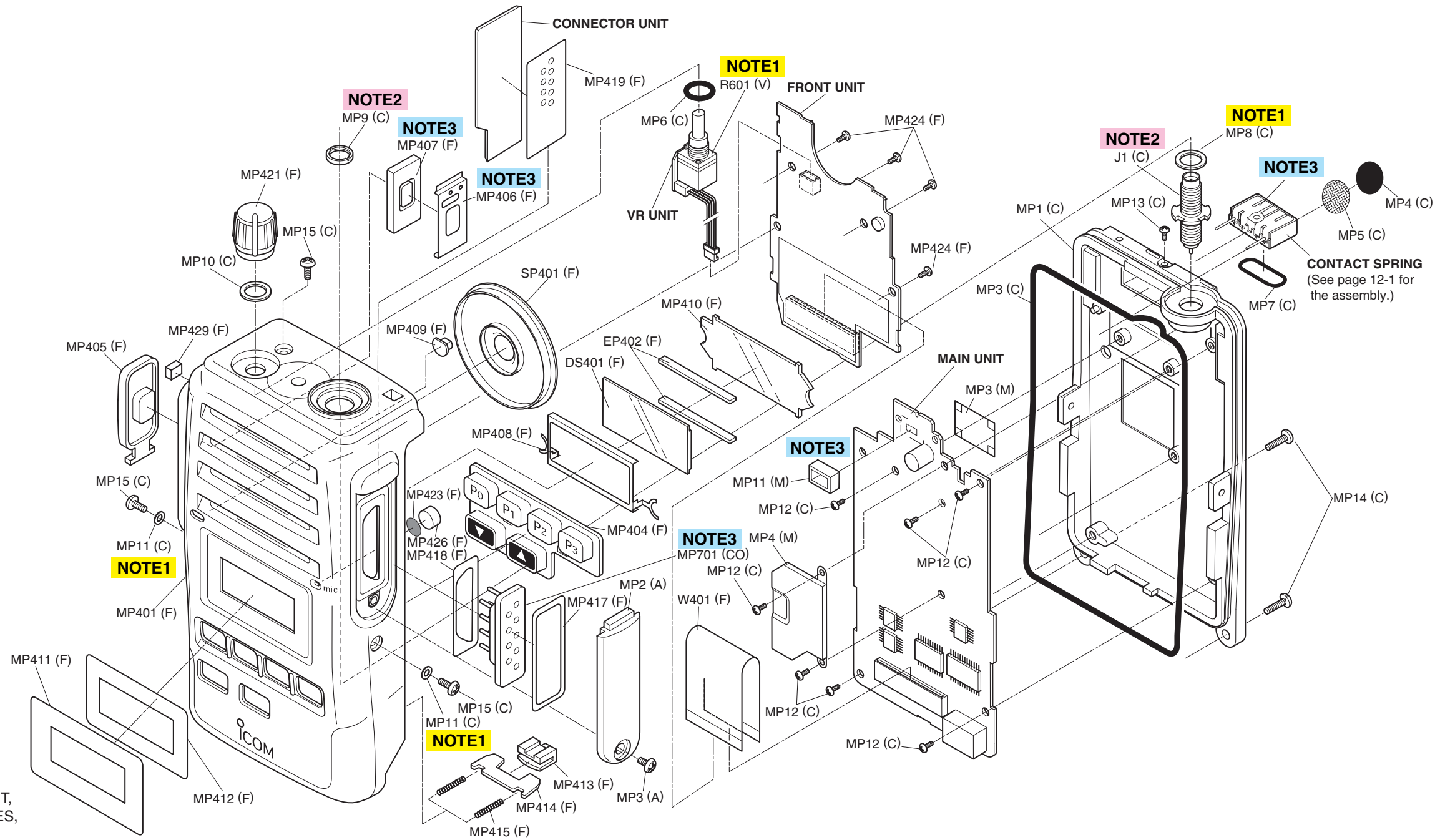
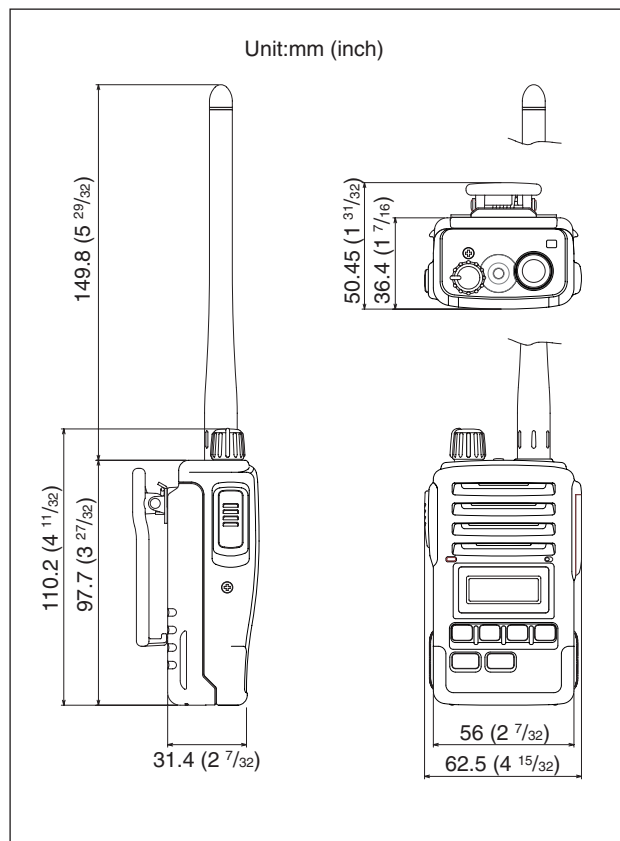

UNIT abbreviations (C): CHASSIS PARTS, (M): MAIN UNIT, (CO): CONNECTOR UNIT, (V): VR UNIT, (A): ACCESSORIES, (F): FRONT UNIT

NOTE1: Once the following parts are removed, an O ring or sealing washer must be replaced with new one before reattachment.

REF. NO.	Mother parts	Daughter parts for related replacement
MP8 (C)	2600 ant connector (J1)	O ring
MP11 (C)	MP15 (C) Screw	Sealing washer (W)
MP6 (C)	S1 (C) Encoder	O ring (AB)

NOTE2
Apply a screw lock in the conclusion with J1 (C) and MP9 (C).
Reference No. : 89500001350
Reference Name : Screw lock 1401B

NOTE3 The glue must be applied to the  areas when the front panel is replaced with new one, to ensure water tightness.

Manufacture : Cemedine Co.
Type : Super-X

A basis to install a speaker

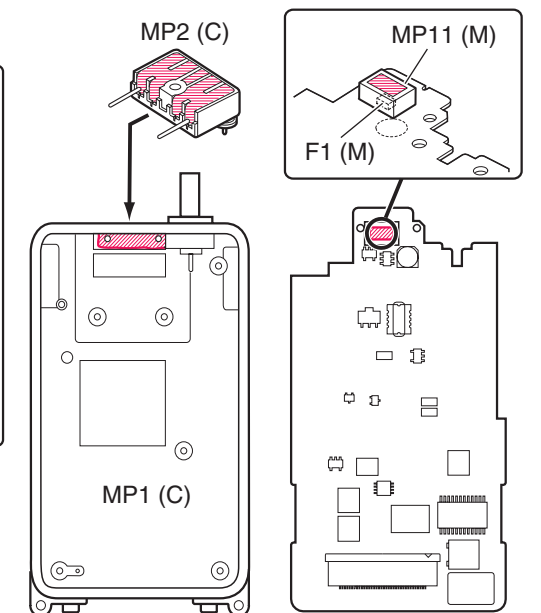
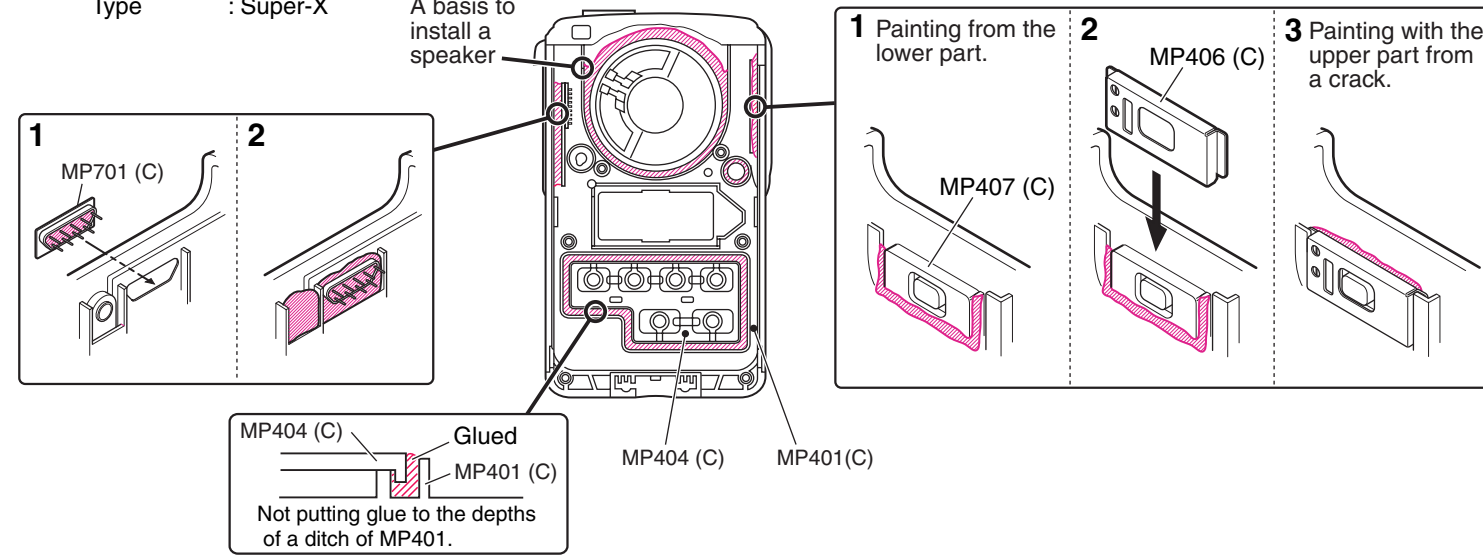

SECTION 8 SEMI-CONDUCTOR INFORMATION

• TRANSISTOR AND FET'S

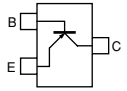
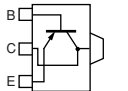
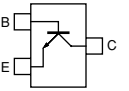
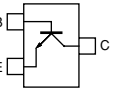
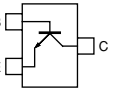
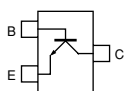
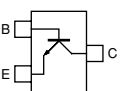
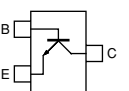
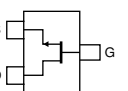
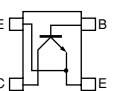
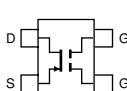
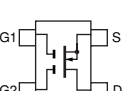
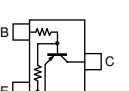
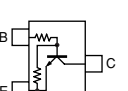
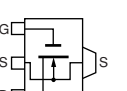
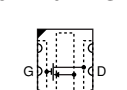
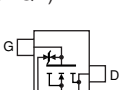
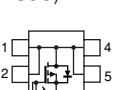
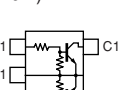
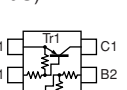
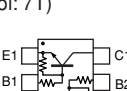
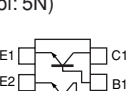
2SA1577 Q (Symbol: HP) 	2SB1132 Q (Symbol: BAQ) 	2SC4116 BL (Symbol: LL) 	2SC4116 Y (Symbol: LY) 	2SC4215 O (Symbol: QO) 
2SC4226 R25 (Symbol: R25) 	2SC5107 O (Symbol: MFO) 	2SC5110 O (Symbol: MGO) 	2SK880 Y (Symbol: XY) 	2SK1829 (Symbol: K1) 
3SK293 (Symbol: UF) 	3SK299 (Symbol: U73) 	DTA144 EU (Symbol: 16) 	DTC144EU (Symbol: 26) 	RD01MUS1 (Symbol: K2) 
RD07MVS1 (Symbol: RD07MVS1) 	RSR025N03 (Symbol: QY) 	TPC6103 (Symbol: S3C) 	XP1214 (Symbol: 9H) 	XP4111 (Symbol: 9U) 
XP4312 (Symbol: 7T) 	XP6501 AB (Symbol: 5N) 			

• DIODES

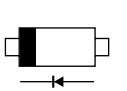
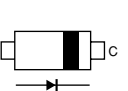
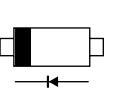
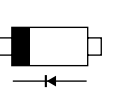
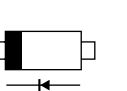
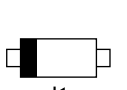
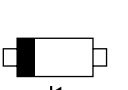
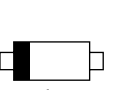
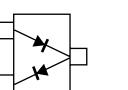
1SV239 (Symbol: TC) 	1SV307 (Symbol: TX) 	HVC350B (Symbol: B0) 	HVC375B (Symbol: B8) 	HVC376B (Symbol: B9) 
MA2S077 (Symbol: S) 	MA2S111 (Symbol: A) 	MA2S728 (Symbol: B) 	RB706F- 40 (Symbol: 3J) 	

SECTION 9 BOARD LAYOUTS

9-1 MAIN UNIT

● TOP VIEW

J1
to the FRONT unit J401

38	GND
36	VCC
	VCC
	NC
	+5V
	S5V
	GND
	GND
	PWON
	CSFT
	DAST
	MROF
	MDIA
	UNLK
	TEMP
	RSSI
	LVIN
	KR1
	CDEC
	SDEC
	NOIS
	MTCK
	MTOT
	EXOE
	EXSM
	SCAT
	PLST
	SCST
	MSCK
	MDIO
	SCK
	SO
	SIGNAL
	CDCS
	TONE
	GND
1	MIC
	GND
37	

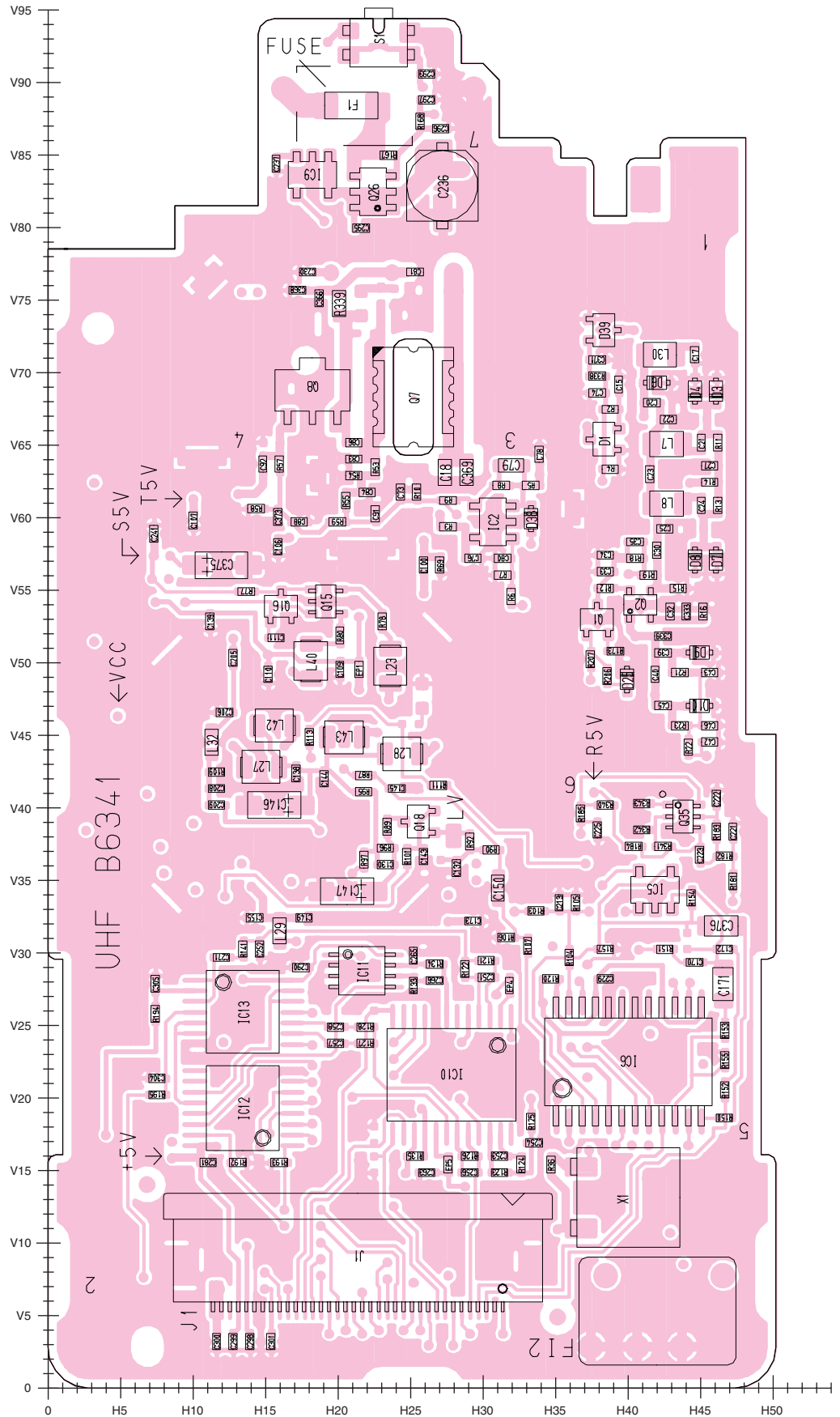

● BOTTOM VIEW

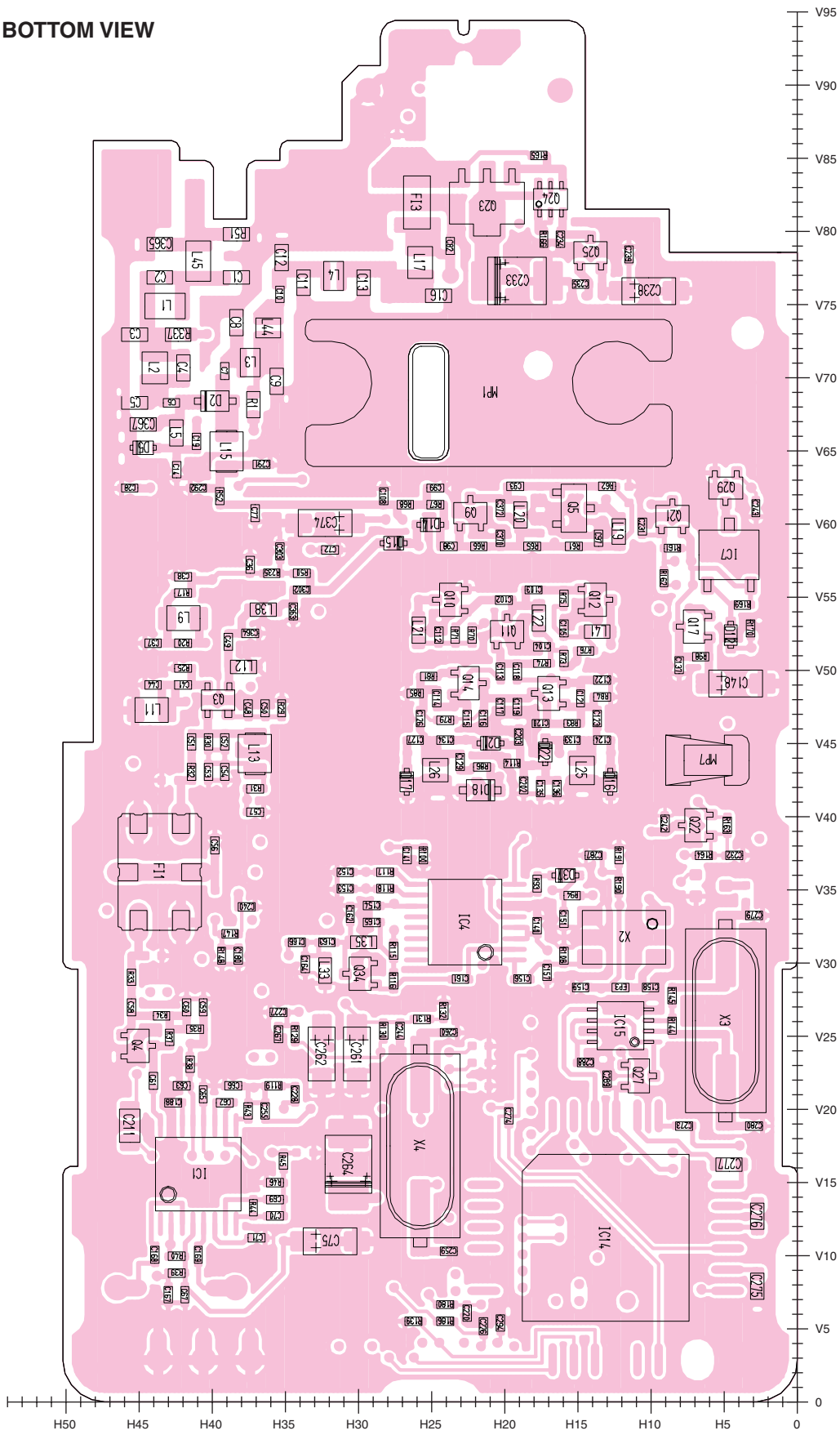

9-2 FRONT UNIT

● TOP VIEW

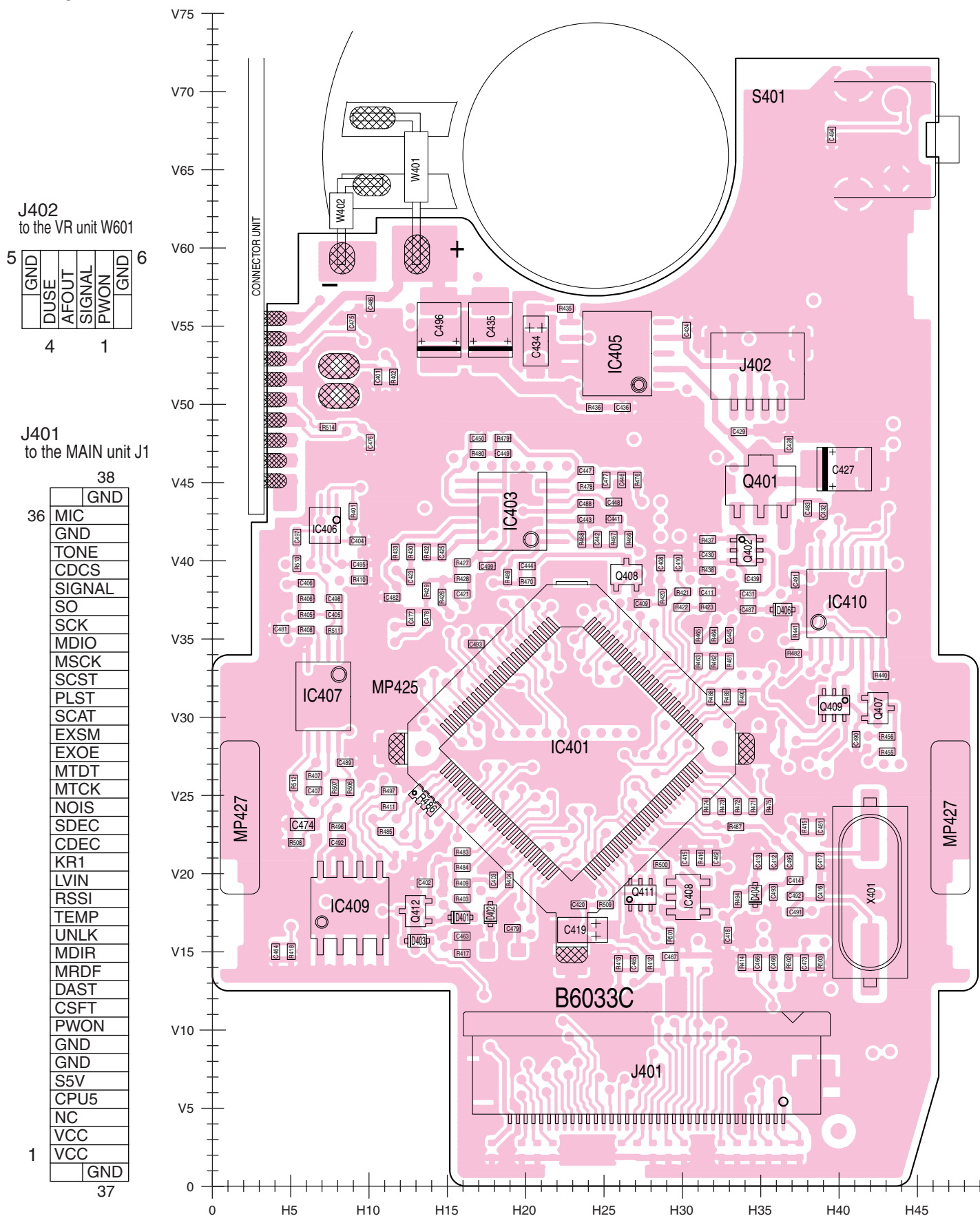

● BOTTOM VIEW

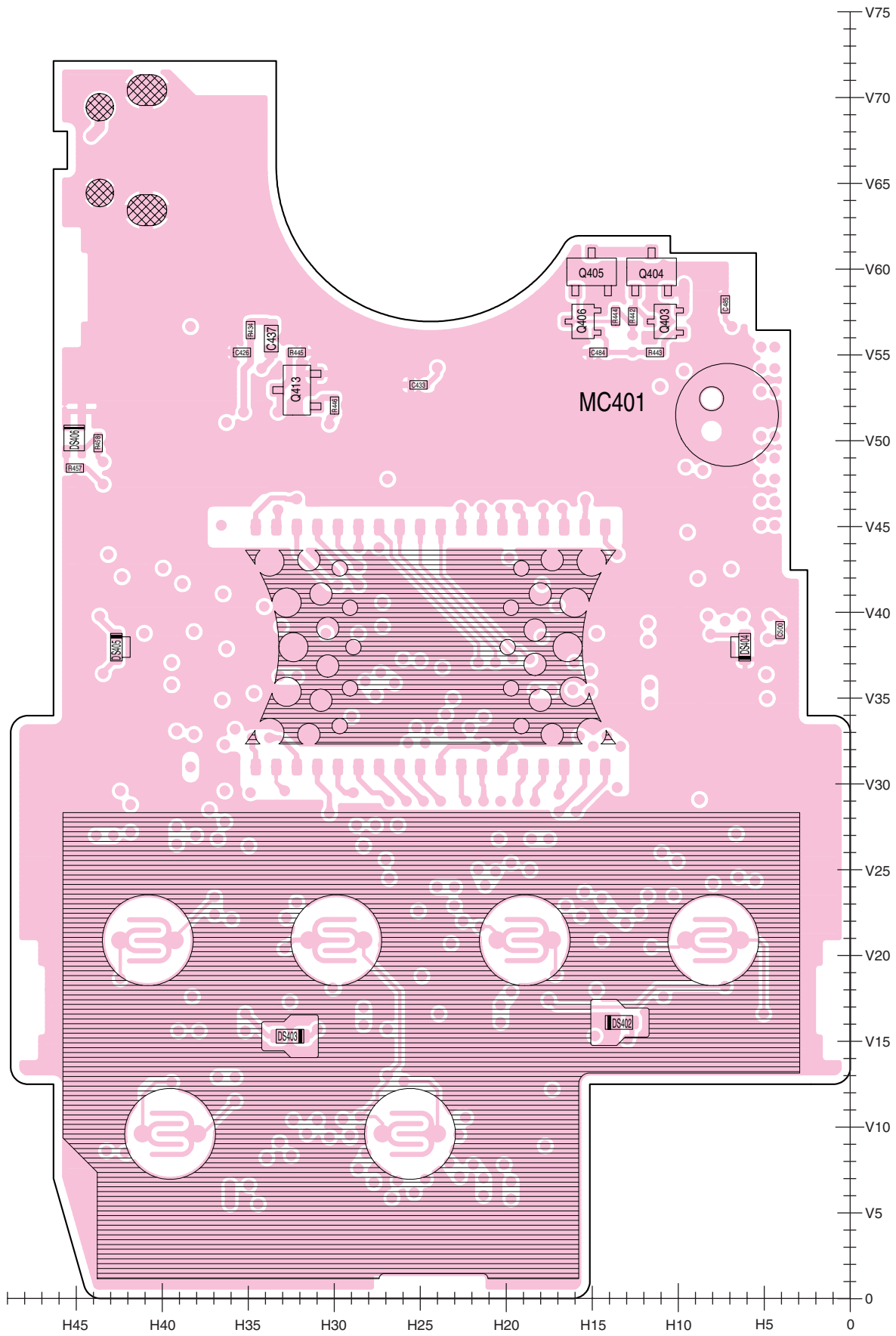

9-3 VR UNIT

● TOP VIEW

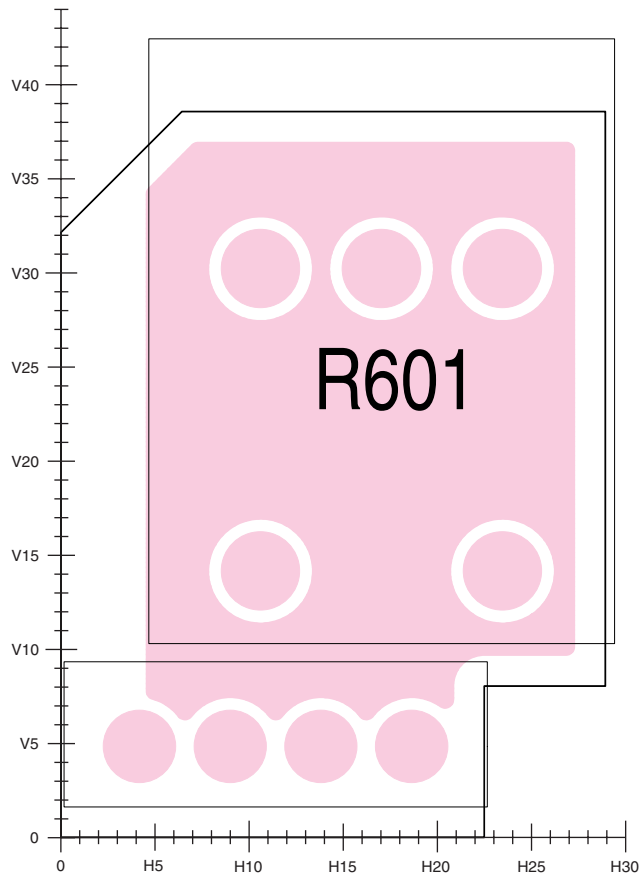

● BOTTOM VIEW

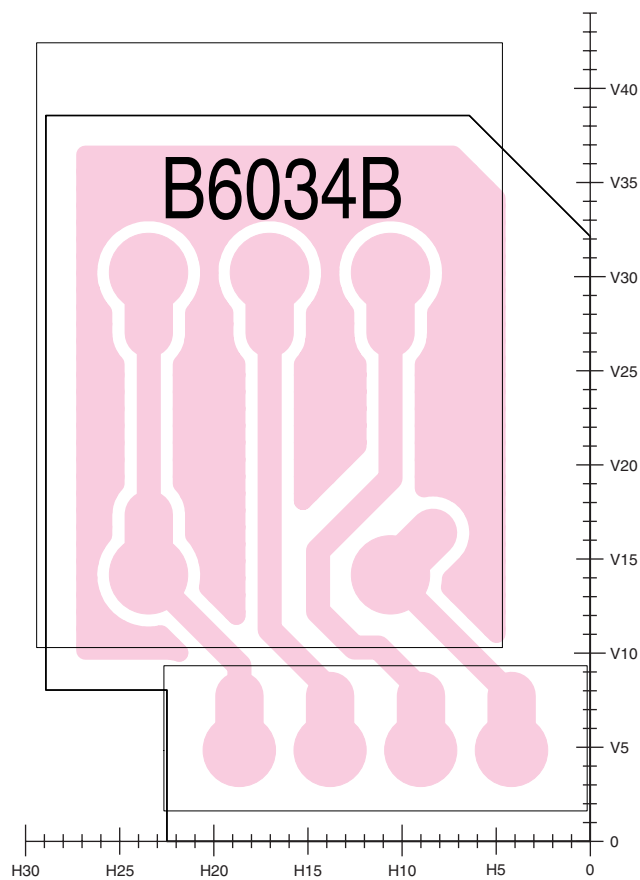

W601
to the FRONT UNIT J402

DUSE	AFOUT	AFON	PWON
4			1

9-4 CONNECTOR UNIT

● TOP VIEW

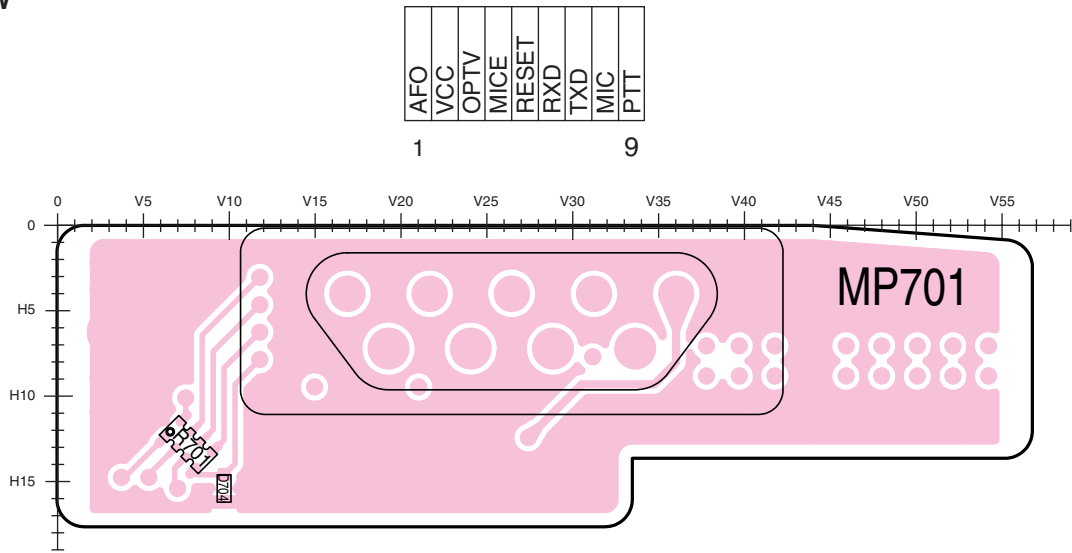

● BOTTOM VIEW

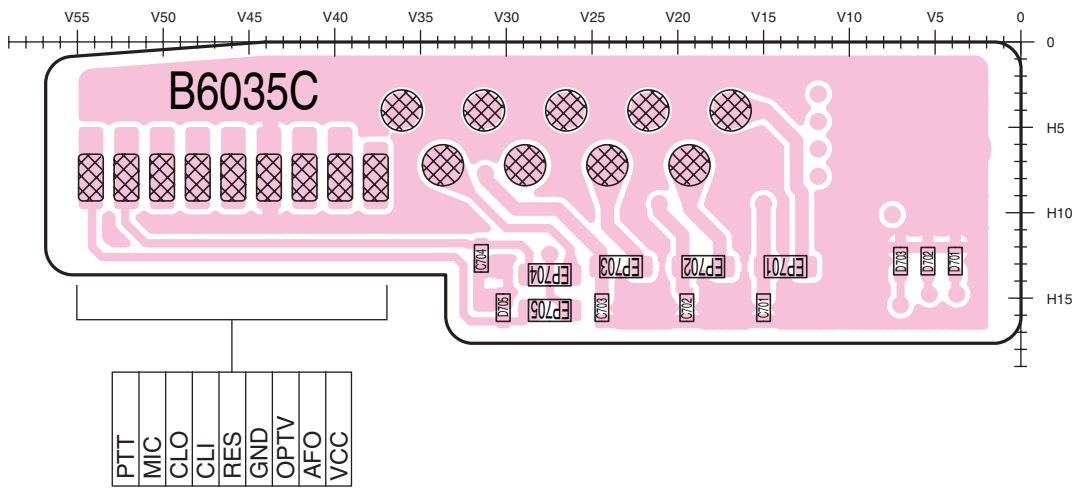

SECTION 10 BLOCK DIAGRAM

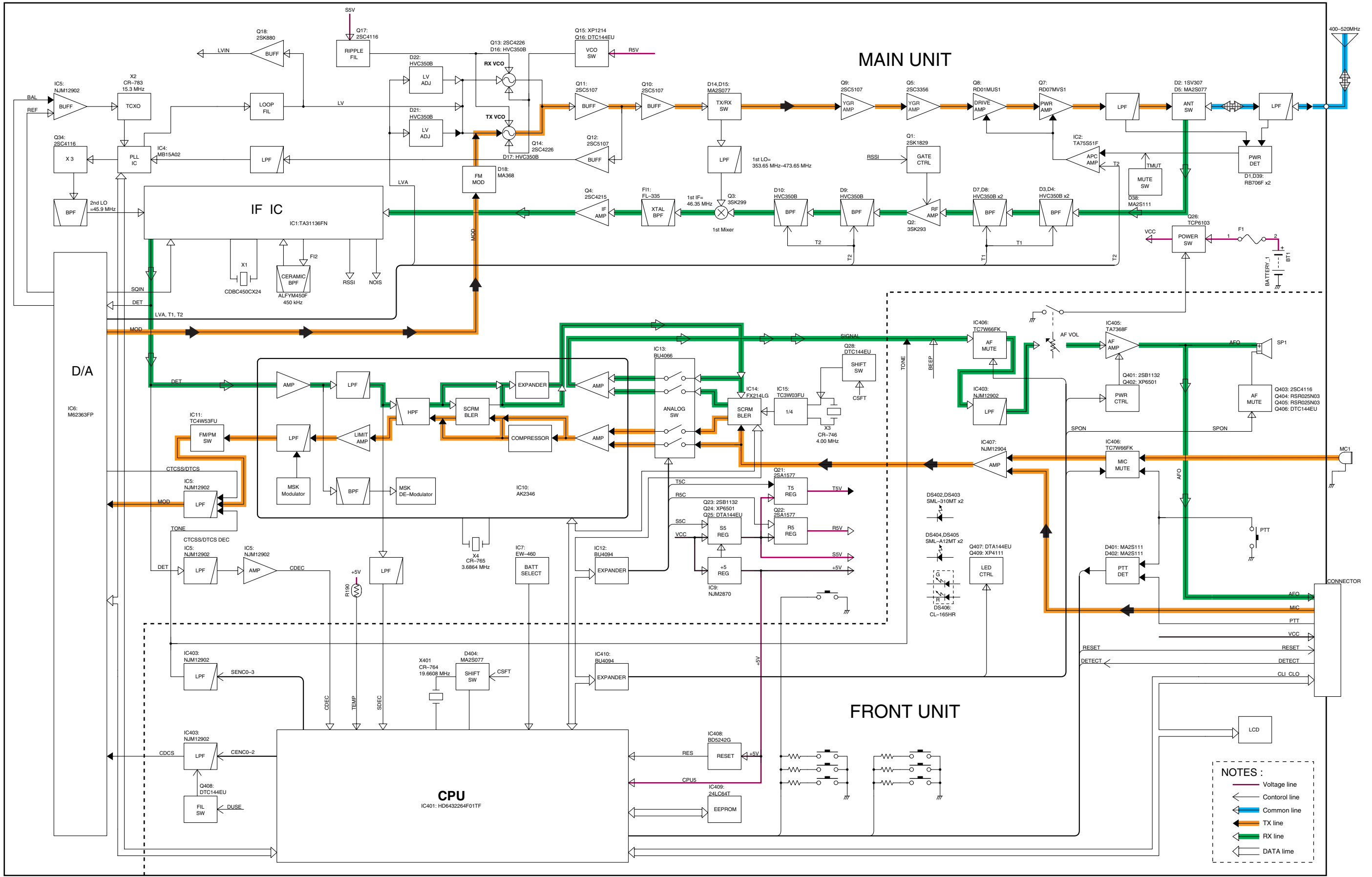

SECTION 11 VOLTAGE DIAGRAM

11-1 MAIN UNIT

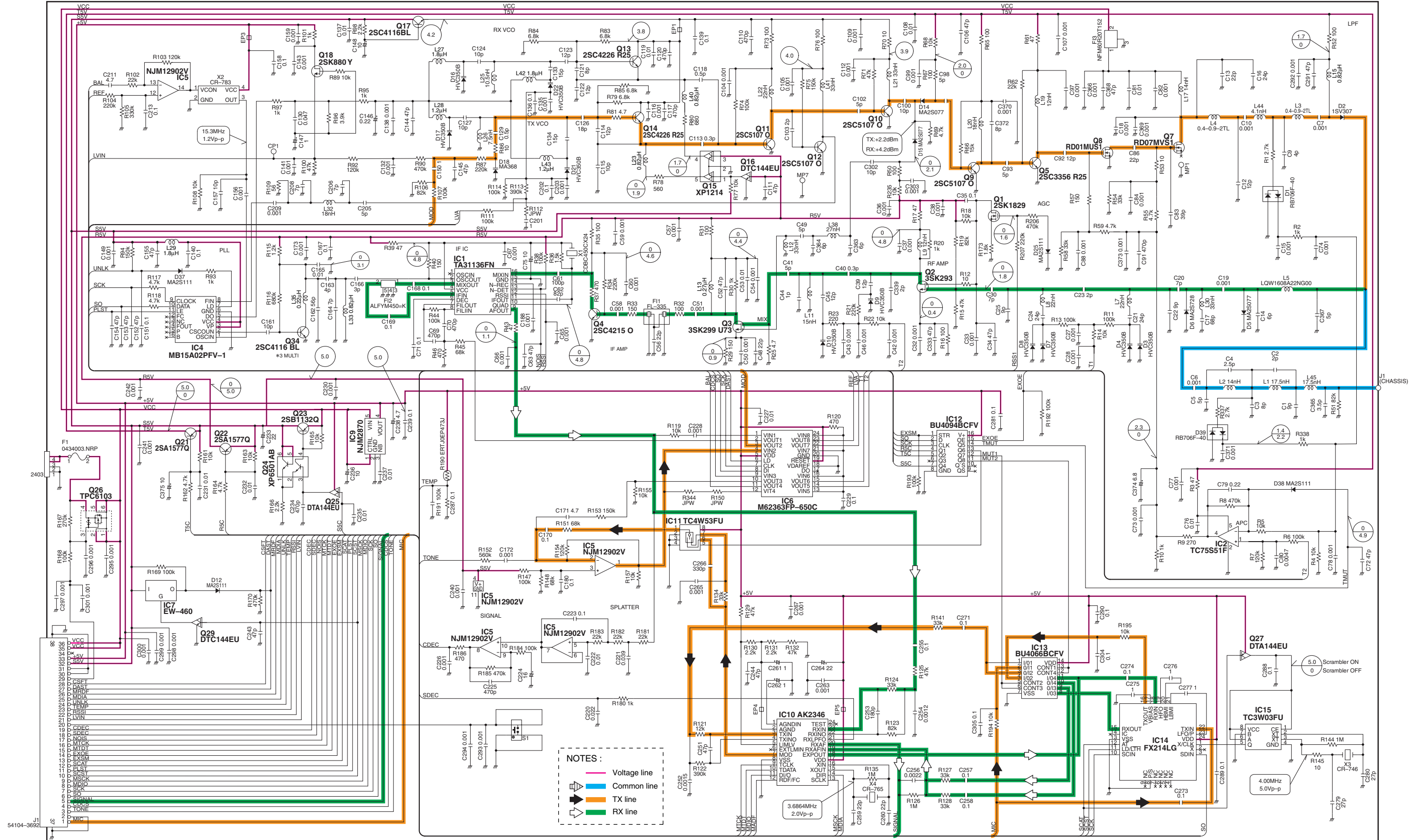

11-2 FRONT UNIT

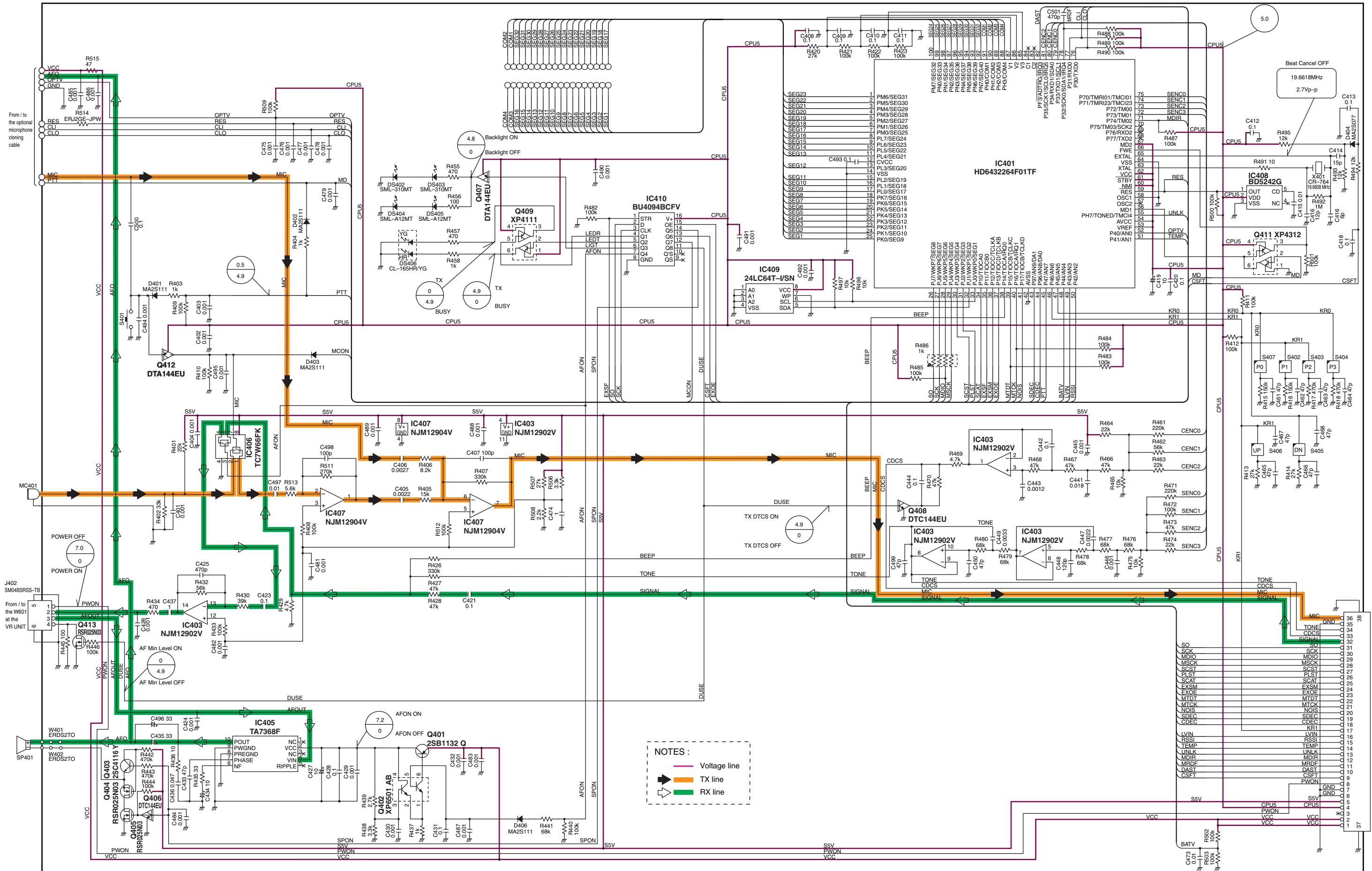

NOTES :

- Voltage line
- TX line
- RX line

J401
54104-3692
From / to the
MAIN unit J1

VR UNIT

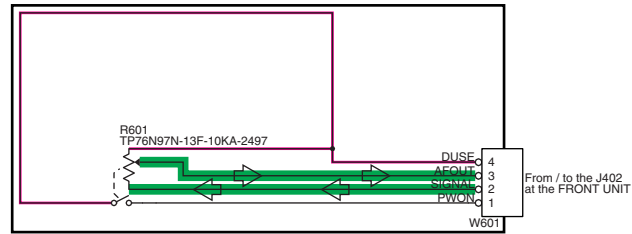

CONNECTOR UNIT

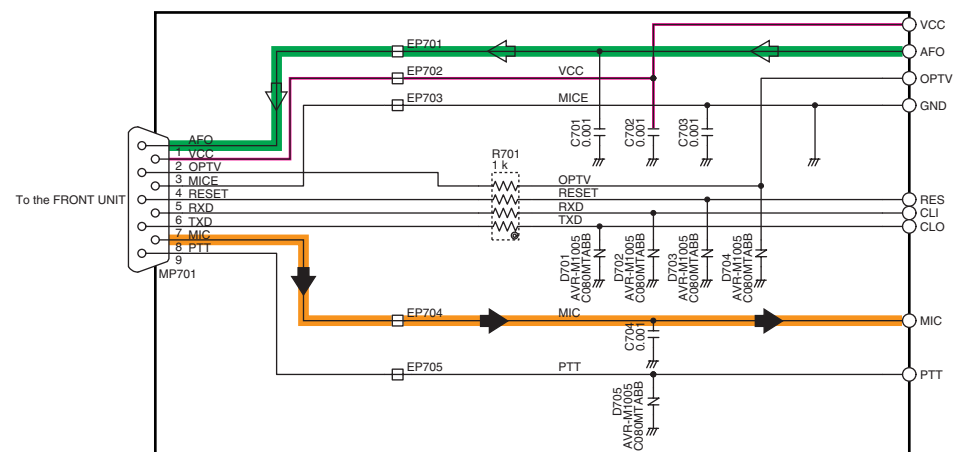

NOTES :

- Voltage line
- TX line
- ← RX line

SECTION 12 CONTACT SPRING ASSEMBLY INSTRUCTION

[1] PREPARING TWO SHORT LEADS

① Cut the W1 (CHASSIS).

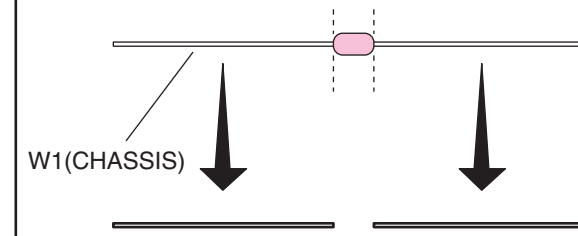

② Bend the leads according to the dimensions below.

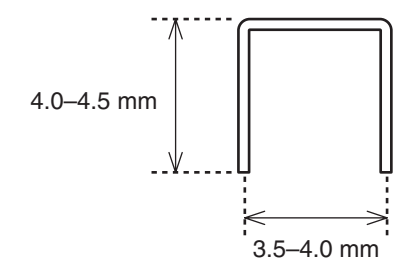

[2] SOLDERING SHORT LEADS

① Cut off the area as below.

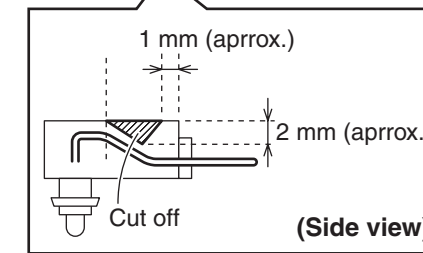
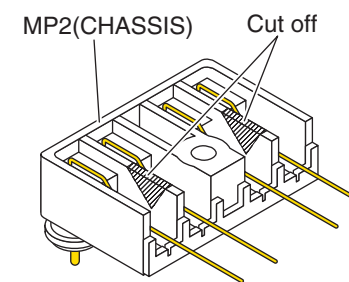

② Solder the short leads.

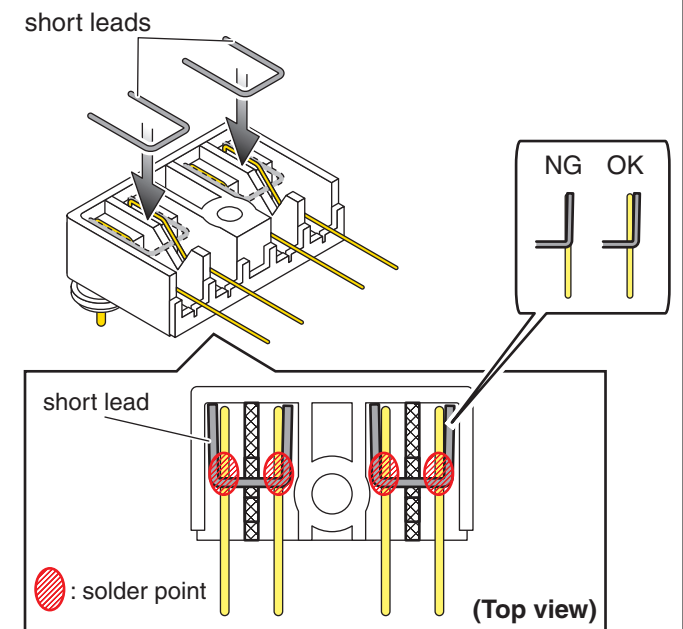

[3] ADDING THE GLUE AND CUTTING OFF EXTRA LEADS

① Fill up the MP2 with glue completely.

CAUTION DO NOT apply the glue to the area except . DO NOT overflow the glue.

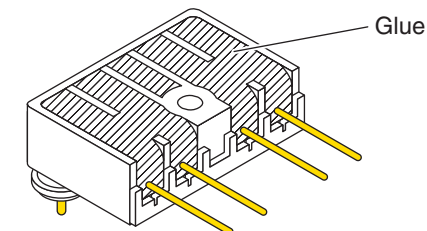

- Glue Type-
Manufacture: Cemedine Co.
Type: Super-X

② Cut off two inner leads from the bottom.

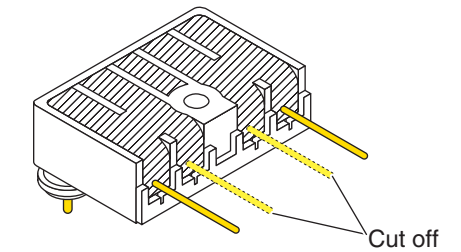

Icom Inc.

1-1-32, Kamiminami, Hirano-ku, Osaka 547-0003, Japan
Phone : +81 (06) 6793 5302
Fax : +81 (06) 6793 0013
URL : <http://www.icom.co.jp/world/index.html>

Icom America Inc.

<Corporate Headquarters>
2380 116th Avenue N.E., Bellevue, WA 98004, U.S.A.
Phone : +1 (425) 454-8155 Fax : +1 (425) 454-1509
URL : <http://www.icomamerica.com>
E-mail : sales@icomamerica.com
<Customer Service>
Phone : +1 (425) 454-7619

Icom Canada

Glenwood Centre #150-6165
Highway 17 Delta, B.C., V4K 5B8, Canada
Phone : +1 (604) 952-4266 Fax : +1 (604) 952-0090
URL : <http://www.icomcanada.com>
E-mail : info@icomcanada.com

Icom (Australia) Pty. Ltd.

A.B.N. 88 006 092 575
Unit 1 / 103 Garden Road, Clayton VIC 3168 Australia
Phone : +61 (03) 9549-7500 Fax : +61 (03) 9549-7505
URL : <http://www.icom.net.au>
E-mail : sales@icom.net.au

Icom New Zealand

146A Harris Road, East Tamaki,
Auckland, New Zealand
Phone : +64 (09) 274 4062 Fax : +64 (09) 274 4708
URL : <http://www.icom.co.nz>
E-mail : inquiries@icom.co.nz

Beijing Icom Ltd.

Room C01, 10th Floor, Long Silver Mansion, No. 88,
Yong Ding Road, Haidian District, Beijing, 100039, China
Phone : +86 (010) 5889 4250 Fax : +86 (010) 5889 4250
URL : <http://www.bjicom.com>
E-mail : bjicom@bjicom.com

Icom (Europe) GmbH

Communication Equipment
Himmelgeister Str. 100, D-40225 Düsseldorf, Germany
Phone : +49 (0211) 346047 Fax : +49 (0211) 333639
URL : <http://www.icomeurope.com>
E-mail : info@icomeurope.com

Icom Spain S.L

Ctra. Rubi, 88, 08190, Sant Cugat del Valles, Barcelona, SPAIN
Phone : +34 (93) 590 26 70 Fax : +34 (93) 589 04 46
URL : <http://www.icomspain.com>
E-mail : icom@icomspain.com

Icom (UK) Ltd.

Unit 9, Sea St., Herne Bay, Kent, CT6 8LD, U.K.
Phone : +44 (01227) 741741 Fax : +44 (01227) 741742
URL : <http://www.icomuk.co.uk>
E-mail : info@icomuk.co.uk

Icom France S.a

Zac de la Plaine, 1, Rue Brindejonc des Moulinais
BP 5804, 31505 Toulouse Cedex, France
Phone : +33 (5) 61 36 03 03 Fax : +33 (5) 61 36 03 00
URL : <http://www.icom-france.com>
E-mail : icom@icom-france.com

Asia Icom Inc.

6F No.68, Sec. 1 Cheng-Teh Road, Taipei, Taiwan, R.O.C.
Phone : +886 (02) 2559 1899 Fax : +886 (02) 2559 1874
URL : <http://www.asia-icom.com>
E-mail : sales@asia-icom.com

Icom Polska

Sopot, 3 Maja 54 Poland
Phone : +48 (58) 550 7135 Fax : +48 (58) 551 0484
E-mail : icompolska@icompolska.com.pl

Count on us!